

NOTE:
 OVERALL SHIPPING DIMENSION: 24'-7" L X 8'-0" W X 9'-2" H

ITEM	SIZE	SUGGESTED FUNCTION
1	4"	SPARE
2	6"	FILL
3	1/2"	DRAIN FOR SPILLBOX
4	7 GAL.	SPILLBOX, DWG."SBB002"
5	3"	PRIMARY TANK WORKING VENT
6	18"	ABOVE LIQUID MANHOLE, DWG."MHB005"
7	2"	MECHANICAL GAUGE/SPARE
8	8"	PRIMARY TANK EMERGENCY VENT
9	4"	SPARE
10	2"	RETURN
11	2"	SUPPLY
12	LARGE	LIFTING LUG
13	8"	SECONDARY CONTAINMENT EMERGENCY VENT
14	2"	SECONDARY MONITOR PORT
15	2"	SECONDARY WORKING VENT

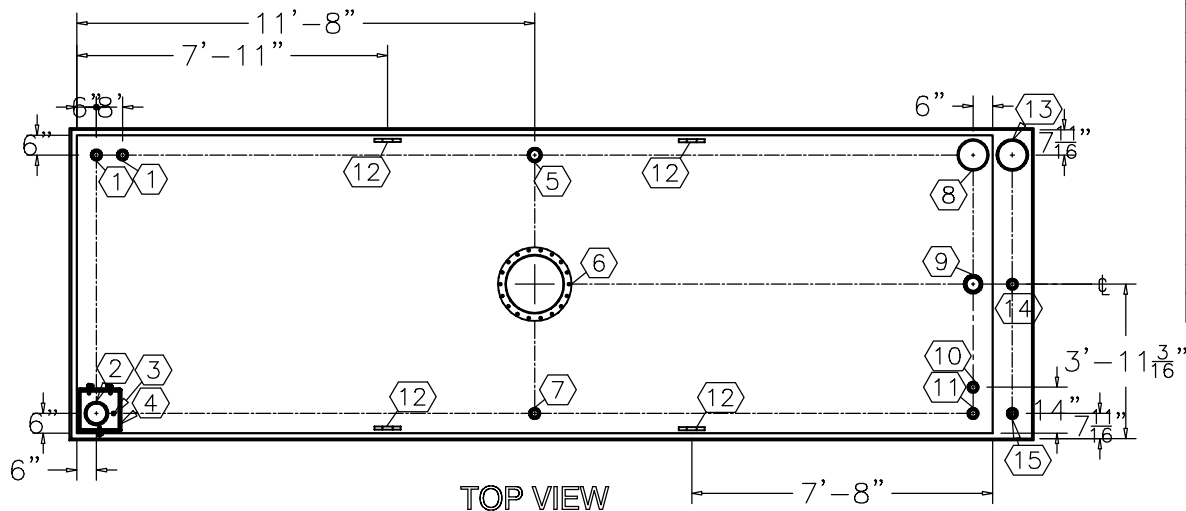

TANK SPECIFICATIONS

VENTING CAPACITY: PRIMARY TANK - 428,000 CUBIC FEET PER HOUR
 SECONDARY TANK - 428,000 CUBIC FEET PER HOUR
 MATERIAL: PRIMARY TANK - 1/4" THICK
 SECONDARY TANK - 3/16" THICK

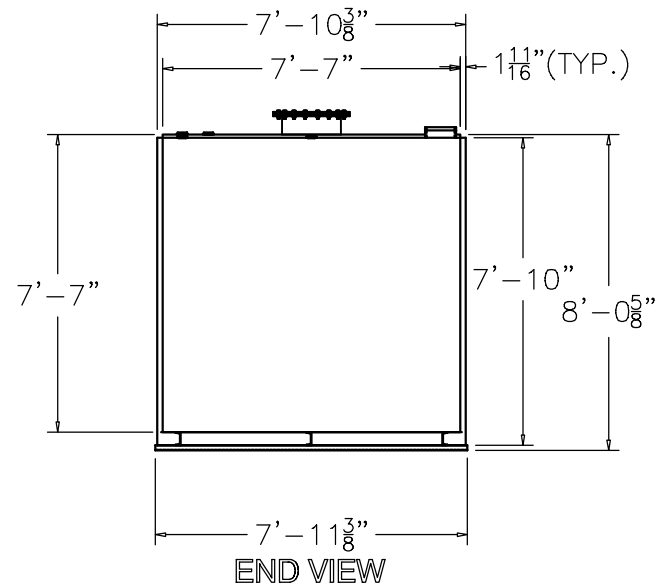
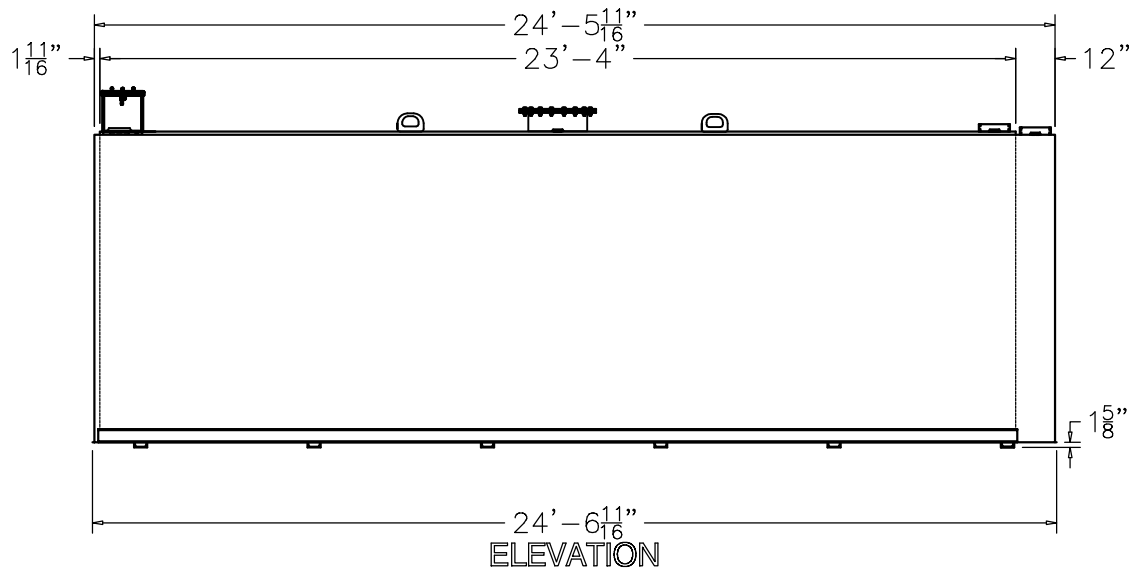

PRODUCT CODE	GALLONS	DESCRIPTION	OVERALL SIZE	SHIP WT.
GCAA110MDS001	10,000	UL-142 DOUBLE WALL GEN CUBE TANK W/SPILLBOX	24'-7" L X 8'-0" W 8'-1" H	16,125 LBS.

THIS DRAWING AND DESIGN SHOWN HEREIN IS THE PROPERTY OF CONTAINMENT SOLUTIONS. USE OR COPIES THEREOF CANNOT BE MADE WITHOUT WRITTEN CONSENT.

CUSTOMER NAME: _____

APPROVED BY: _____ DATE: _____

CONTAINMENT SOLUTIONS®

DRAWN BY: D.ROVANG	DATE DRAWN: 01-01-14
DWG NUMBER: 5104016	SCALE: 1:60
REV: _____	REV BY: _____
DATE: _____	SHEET: 1 OF 1