

NOTE:
OVERALL SHIPPING DIMENSION: 31'-0" L X 8'-6" W X 8'-0" H

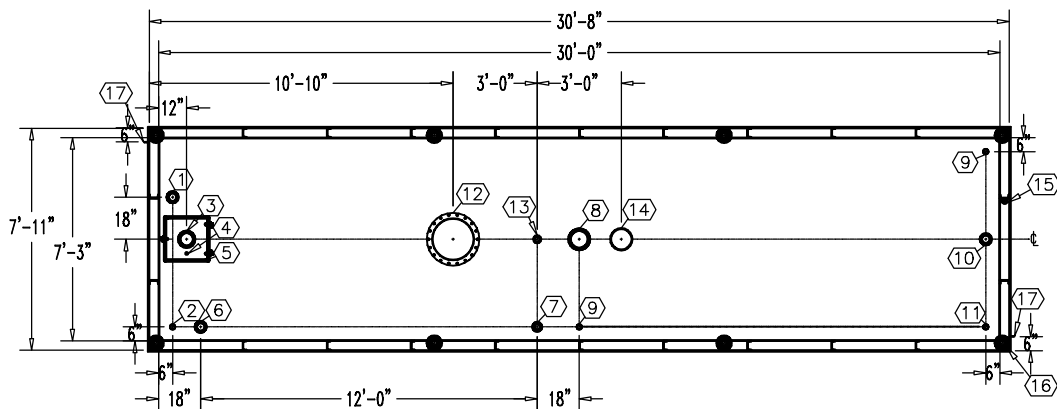

TOP VIEW

ITEM	SIZE	SUGGESTED FUNCTION
1	4"	PHASE 1 VAPOR RECOVERY/SPARE
2	2"	MECHANICAL GAUGE
3	6"	FILL
4	1/2"	DRAIN FOR SPILLBOX
5	15 GAL.	SPILLBOX, DWG."SBB001"
6	4"	ELECTRONIC LEVEL GAUGE
7	3"	PRIMARY WORKING VENT
8	8"	PRIMARY TANK EMERGENCY VENT
9	2"	SPARE
10	4"	SUBMERSIBLE PUMP
11	2"	SUCTION PUMP/SPARE
12	18"	ABOVE LIQUID MANHOLE, DWG."MH001"
13	2"	SECONDARY WORKING VENT
14	8"	SECONDARY CONTAINMENT EMERGENCY VENT
15	2"	SECONDARY MONITOR PIPE
16	4"	FIRE RATED MATERIAL FILL
17	2" X 2"	GROUND CLIP, DWG."MCB004"

TANK SPECIFICATIONS

VENTING CAPACITY: PRIMARY TANK - 428,000 CUBIC FEET PER HOUR
 SECONDARY TANK - 462,000 CUBIC FEET PER HOUR
 MATERIAL: PRIMARY TANK - 1/4" THICK
 SECONDARY TANK - 3/16" THICK

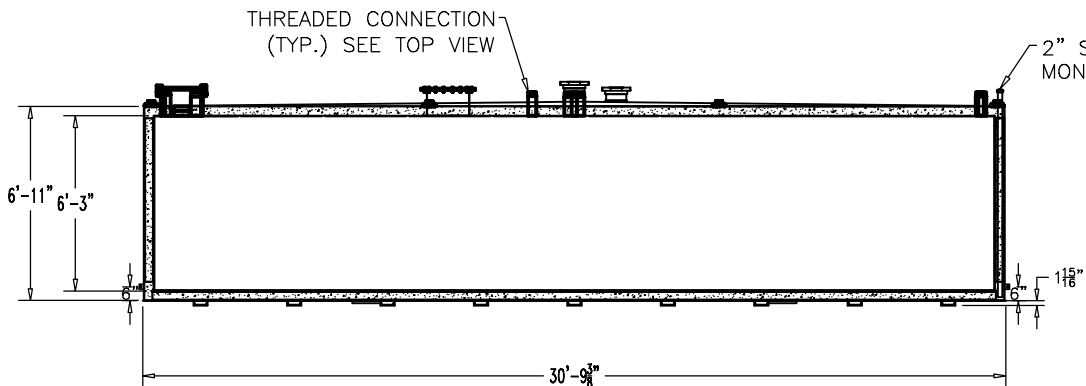

ELEVATION

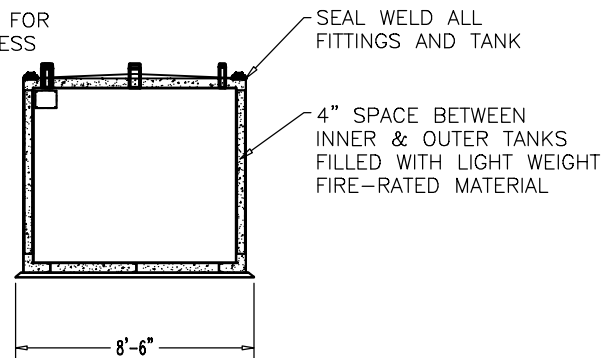

END VIEW

PRODUCT CODE	GALLONS	DESCRIPTION	OVERALL SIZE	SHIP WT.
V4AA110MVS001	10,000	U/L-2085 ABOVE GROUND VAULT TANK W/SPILLBOX	30'-8" L X 7'-11" W X 7'-1" H	42,600 LBS.



THIS DRAWING AND DESIGN SHOWN HEREIN IS THE PROPERTY OF CONTAINMENT SOLUTIONS. USE OR COPIES THEREOF CANNOT BE MADE WITHOUT WRITTEN CONSENT.

CUSTOMER NAME: _____
APPROVED BY: _____ DATE: _____

DRAWN BY: D. ROVANG	DATE DRAWN: 01-01-14
DWG NUMBER: 5100011	SCALE: 1:84
REV: _____	REV BY: _____
DATE: _____	SHEET: 1 OF 1