

NOTE:
OVERALL SHIPPING DIMENSION: 9'-4" L X 4'-0" W X 6'-2" H

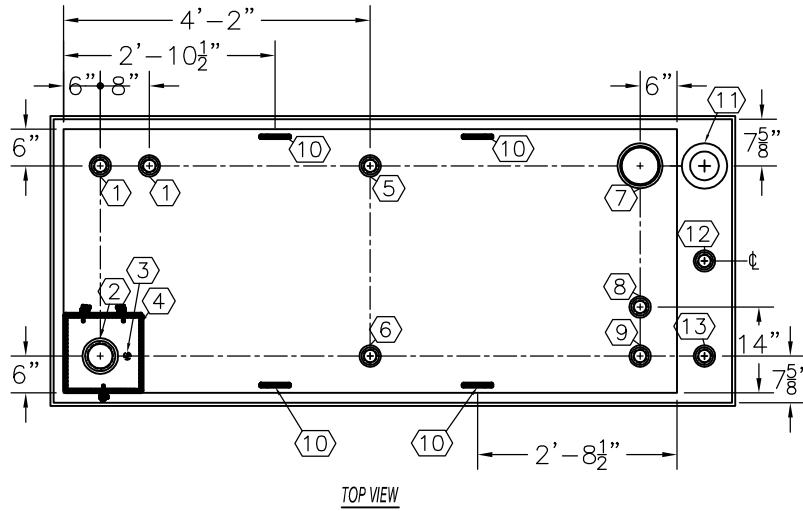

ITEM	SIZE	SUGGESTED FUNCTION
1	2"	SPARE
2	4"	FILL
3	1/2"	DRAIN FOR SPILLBOX
4	7 GAL.	SPILLBOX, DWG."SBB002"
5	2"	PRIMARY TANK WORKING VENT
6	2"	MECHANICAL GAUGE/SPARE
7	6"	PRIMARY TANK EMERGENCY VENT
8	2"	RETURN
9	2"	SUPPLY
10	SMALL	LIFTING LUG
11	6"	SECONDARY CONTAINMENT EMERGENCY VENT
12	2"	SECONDARY MONITOR PORT
13	2"	SECONDARY WORKING VENT

TANK SPECIFICATIONS

VENTING CAPACITY: PRIMARY TANK - 147,000 CUBIC FEET PER HOUR
 SECONDARY TANK - 168,000 CUBIC FEET PER HOUR
 MATERIAL: PRIMARY TANK - 10 GA.
 SECONDARY TANK - 10 GA.

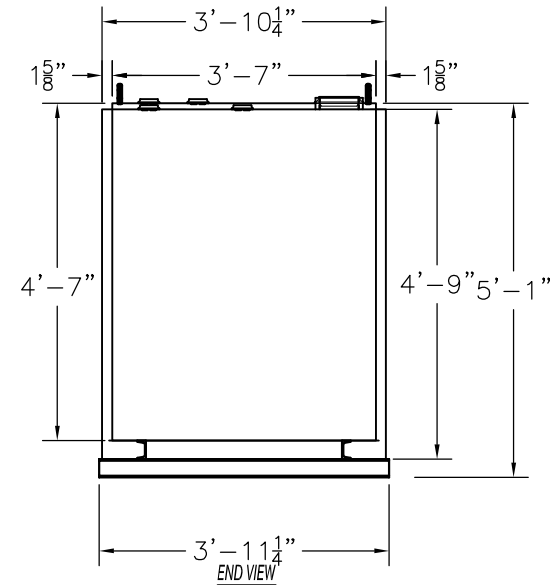
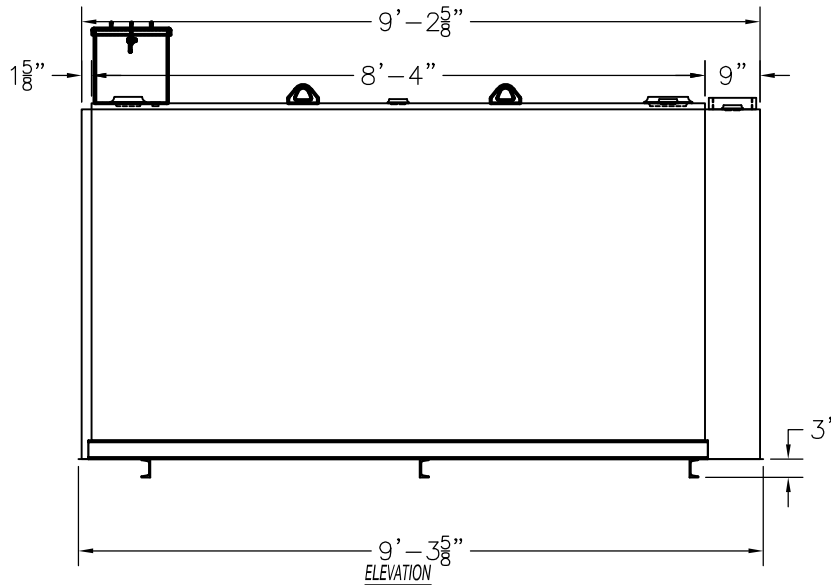

PRODUCT CODE	GALLONS	DESCRIPTION	OVERALL SIZE	SHIP WT.
GCAA101MDS001	1,000	UL-142 DOUBLE WALL GEN CUBE TANK W/SPILLBOX	9'-4" L X 4'-0" W X 5'-1" H	2,400 LBS.



THIS DRAWING AND DESIGN SHOWN HEREIN IS THE PROPERTY OF CONTAINMENT SOLUTIONS. USE OR COPIES THEREOF CANNOT BE MADE WITHOUT WRITTEN CONSENT.

CUSTOMER NAME: _____
APPROVED BY: _____ DATE: _____

DRAWN BY: D. ROVANG	DATE DRAWN: 01-01-14
DWG NUMBER: 5104007	SCALE: 1:32
REV: _____	REV BY: _____
DATE: _____	SHEET: 1 OF 1