

NOTE:
OVERALL SHIPPING DIMENSION: 29'-3" L X 8'-0" W X 8'-8" H

ITEM	SIZE	SUGGESTED FUNCTION
1	4"	SPARE
2	6"	FILL
3	3"	PRIMARY TANK WORKING VENT
4	18"	ABOVE LIQUID MANHOLE, DWG."MHB005"
5	2"	MECHANICAL GAUGE/SPARE
6	8"	PRIMARY TANK EMERGENCY VENT
7	2"	SPARE
8	LARGE	LIFTING LUG
9	8"	SECONDARY CONTAINMENT EMERGENCY VENT
10	2"	SECONDARY MONITOR PORT
11	2"	SECONDARY WORKING VENT

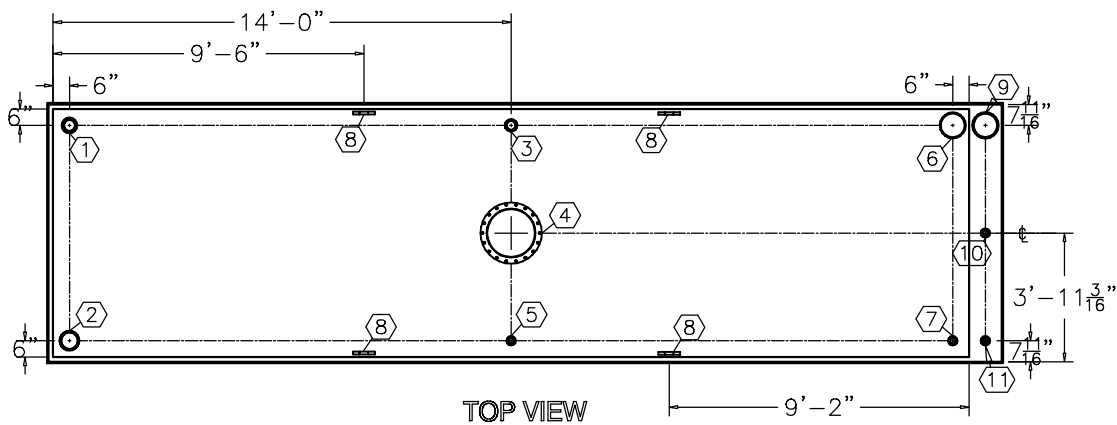

TANK SPECIFICATIONS

VENTING CAPACITY: PRIMARY TANK - 462,000 CUBIC FEET PER HOUR
 SECONDARY TANK - 493,000 CUBIC FEET PER HOUR
 MATERIAL: PRIMARY TANK - 1/4" THICK
 SECONDARY TANK - 3/16" THICK

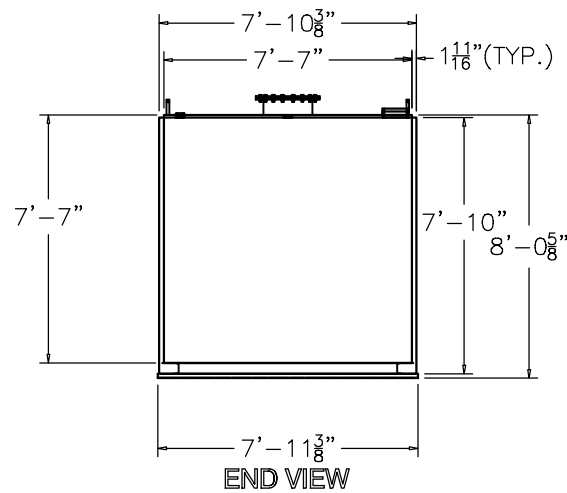
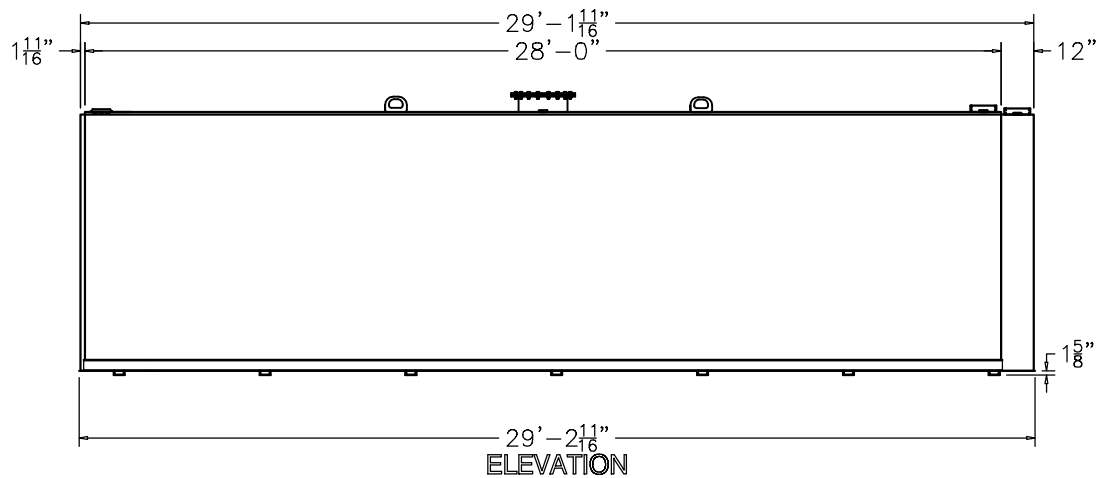

PRODUCT CODE	GALLONS	DESCRIPTION	OVERALL SIZE	SHIP WT.
LCAA112MDS000	12,000	UL-142 DOUBLE WALL LUBE CUBE TANK	29'-3" L X 8'-0" W X 8'-1" H	18,550 LBS.

CONTAINMENT SOLUTIONS

THIS DRAWING AND DESIGN SHOWN HEREIN IS THE PROPERTY OF CONTAINMENT SOLUTIONS. USE OR COPIES THEREOF CANNOT BE MADE WITHOUT WRITTEN CONSENT.

CUSTOMER NAME: _____
APPROVED BY: _____ DATE: _____

DRAWN BY: D. ROVANG DATE DRAWN: 01-01-14
 DWG NUMBER: 5100110 SCALE: 1:72
 REV: _____ REV BY: _____ DATE: _____ SHEET: 1 OF 1