

NOTE:
 OVERALL SHIPPING DIMENSION: 29'-3" L X 8'-0" W X 9'-2" H

ITEM	SIZE	SUGGESTED FUNCTION
1	4"	SPARE
2	6"	FILL
3	1/2"	DRAIN FOR SPILLBOX
4	7 GAL.	SPILLBOX, DWG."SBB002"
5	3"	PRIMARY TANK WORKING VENT
6	18"	ABOVE LIQUID MANHOLE, DWG."MHBO05"
7	2"	MECHANICAL GAUGE/SPARE
8	8"	PRIMARY TANK EMERGENCY VENT
9	2"	SPARE
10	LARGE	LIFTING LUG
11	8"	SECONDARY CONTAINMENT EMERGENCY VENT
12	2"	SECONDARY MONITOR PORT
13	2"	SECONDARY WORKING VENT

TANK SPECIFICATIONS

VENTING CAPACITY: PRIMARY TANK - 462,000 CUBIC FEET PER HOUR

SECONDARY TANK - 493,000 CUBIC FEET PER HOUR

MATERIAL: PRIMARY TANK - 1/4" THICK

SECONDARY TANK - 3/16" THICK

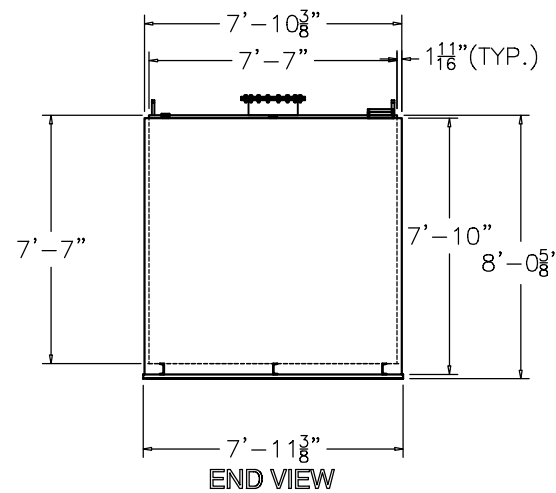
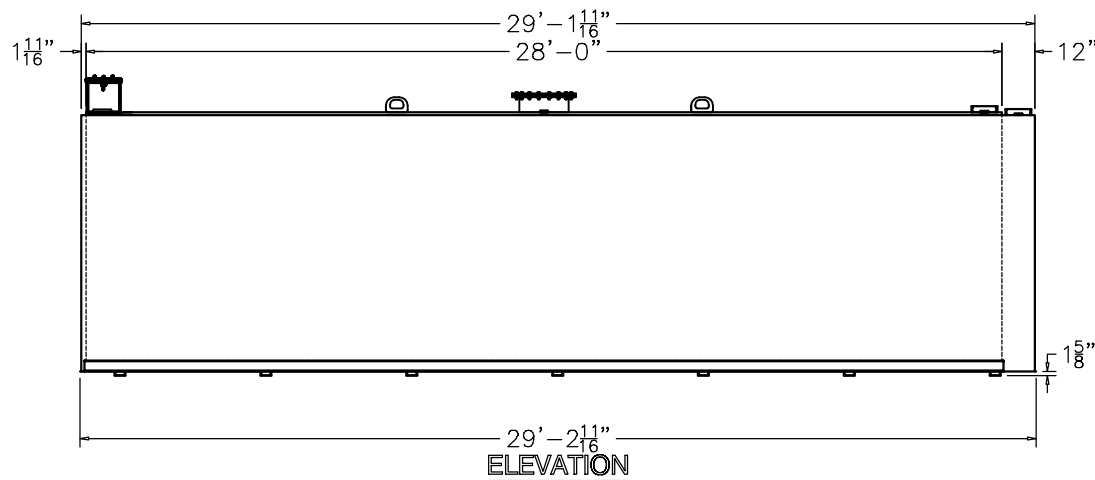
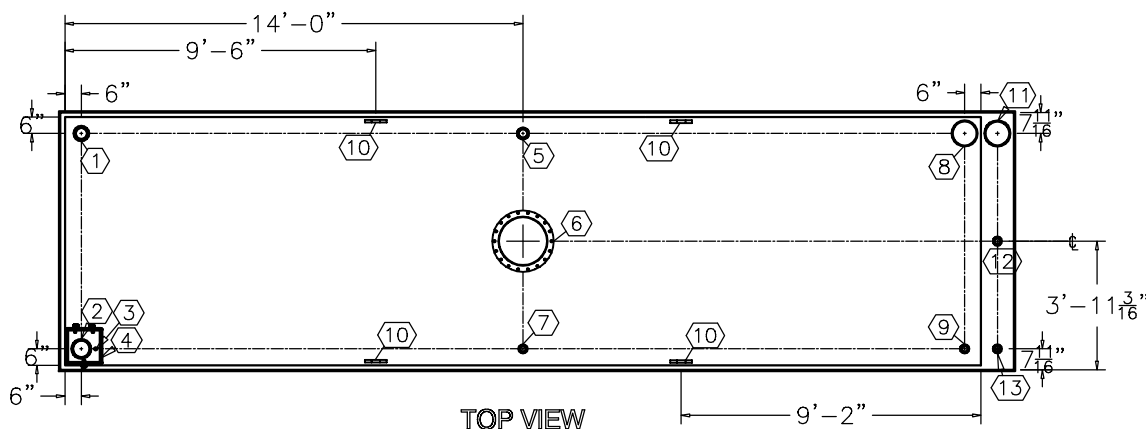

PRODUCT CODE	GALLONS	DESCRIPTION	OVERALL SIZE	SHIP WT.
LCAA112MDS001	12,000	UL-142 DOUBLE WALL LUBE CUBE TANK W/SPILLBOX	29'-3" L X 8'-0" W 8'-1" H	18,550 LBS.



THIS DRAWING AND DESIGN SHOWN HEREIN IS THE PROPERTY OF CONTAINMENT SOLUTIONS. USE OR COPIES THEREOF CANNOT BE MADE WITHOUT WRITTEN CONSENT.

CUSTOMER NAME: _____
APPROVED BY: _____ DATE: _____

DRAWN BY: D.ROVANG	DATE DRAWN: 01-01-14
DWG NUMBER: 5100129	SCALE: 1:72
REV: _____	REV BY: _____
DATE: _____	SHEET: 1 OF 1