

NOTE:
OVERALL SHIPPING DIMENSION: 37'-0" L X 8'-6" W X 8'-0" H

ITEM	SIZE	SUGGESTED FUNCTION
1	4"	PHASE 1 VAPOR RECOVERY/SPARE
2	2"	MECHANICAL GAUGE
3	6"	FILL
4	1/2"	DRAIN FOR SPILLBOX
5	15 GAL.	SPILLBOX, DWG."SBB001"
6	4"	ELECTRONIC LEVEL GAUGE
7	3"	PRIMARY WORKING VENT
8	8"	PRIMARY TANK EMERGENCY VENT
9	2"	SPARE
10	4"	SUBMERSIBLE PUMP
11	2"	SUCTION PUMP/SPARE
12	18"	ABOVE LIQUID MANHOLE, DWG."MHB001"
13	2"	SECONDARY WORKING VENT
14	8"	SECONDARY CONTAINMENT EMERGENCY VENT
15	2"	SECONDARY MONITOR PIPE
16	4"	FIRE RATED MATERIAL FILL
17	2" X 2"	GROUND CLIP, DWG."MCB004"

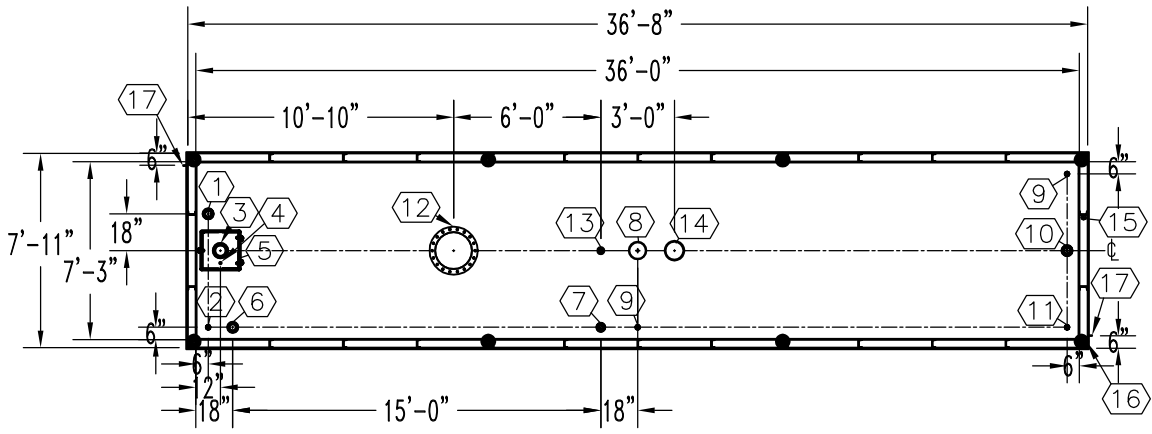

TANK SPECIFICATIONS

VENTING CAPACITY: PRIMARY TANK - 462,600 CUBIC FEET PER HOUR
 SECONDARY TANK - 496,300 CUBIC FEET PER HOUR
 MATERIAL: PRIMARY TANK - 1/4" THICK
 SECONDARY TANK - 3/16" THICK

TOP VIEW
 THREADED CONNECTION (TYP.) SEE TOP VIEW

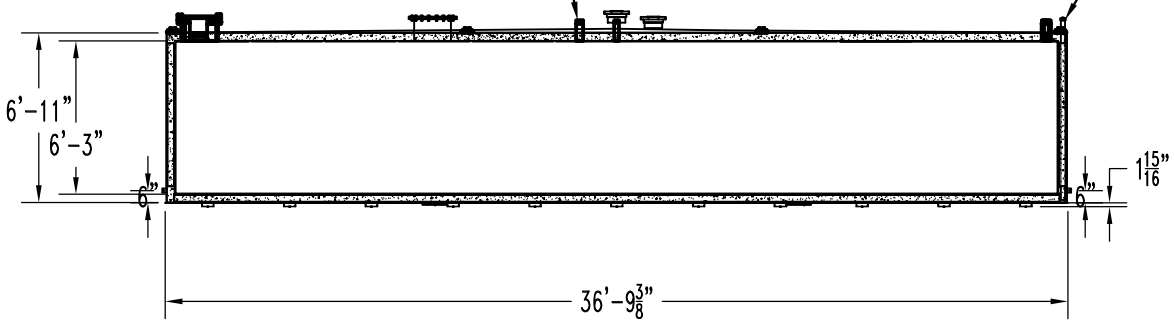

ELEVATION

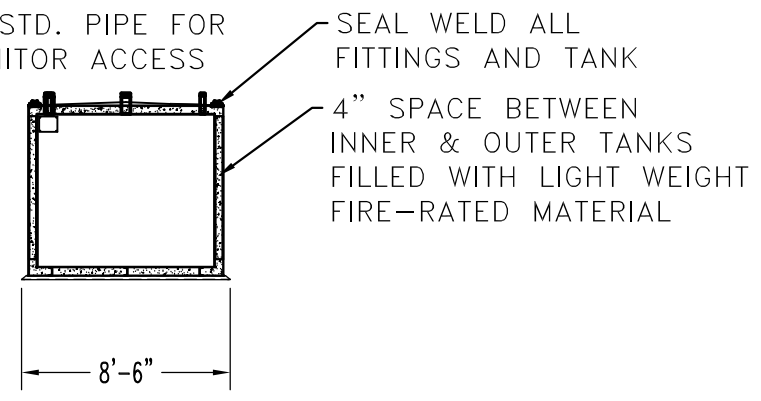

END VIEW

PRODUCT CODE	GALLONS	DESCRIPTION	OVERALL SIZE	SHIP WT.
V4AA112MVS001	12,000	U/L-2085 ABOVE GROUND VAULT TANK W/SPILLBOX	36'-8" L X 7'-11" W X 7'-1" H	48,750 LBS.



THIS DRAWING AND DESIGN SHOWN HEREIN IS THE PROPERTY OF CONTAINMENT SOLUTIONS. USE OR COPIES THEREOF CANNOT BE MADE WITHOUT WRITTEN CONSENT.

CUSTOMER NAME: _____
APPROVED BY: _____ DATE: _____

DRAWN BY: D. ROVANG	DATE DRAWN: 01-01-14
DWG NUMBER: 5100012	SCALE: 1:96
REV: _____	REV BY: _____
DATE: _____	SHEET: 1 OF 1