

NOTE:
OVERALL SHIPPING DIMENSION: 2'-10" L X 2'-10" W X 4'-4" H

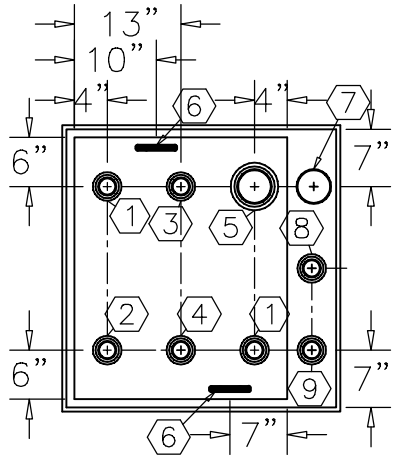

TOP VIEW

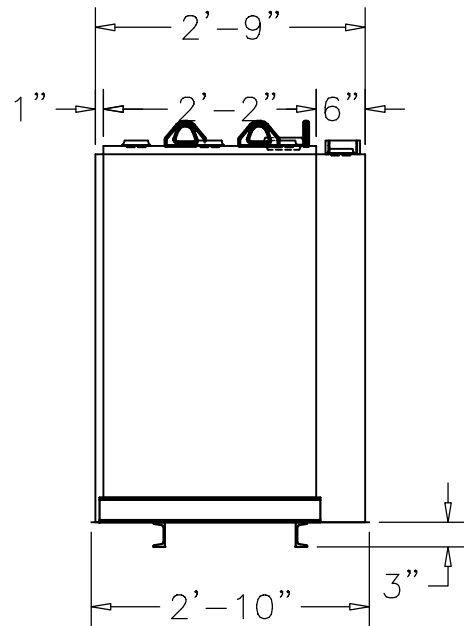

ELEVATION

ITEM	SIZE	SUGGESTED FUNCTION
1	2"	SPARE
2	2"	FILL
3	2"	PRIMARY TANK WORKING VENT
4	2"	MECHANICAL GAUGE/ SPARE
5	4"	PRIMARY TANK EMERGENCY VENT
6	SMALL	LIFTING LUG
7	4"	SECONDARY CONTAINMENT EMERGENCY VENT
8	2"	SECONDARY MONITOR PORT/ SPARE
9	2"	SECONDARY WORKING VENT

TANK SPECIFICATIONS

VENTING CAPACITY: PRIMARY TANK - 42,100 CUBIC FEET PER HOUR

SECONDARY TANK - 52,700 CUBIC FEET PER HOUR

MATERIAL: PRIMARY TANK - 10 GA.

SECONDARY TANK - 10 GA.

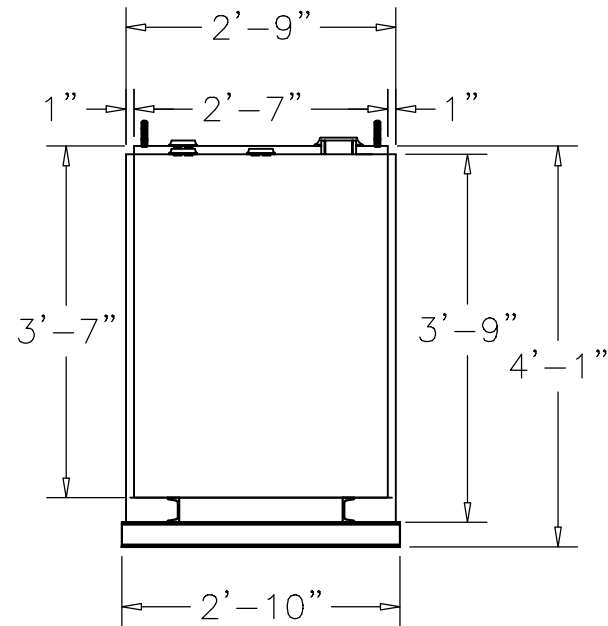

END VIEW

PRODUCT CODE	GALLONS	DESCRIPTION	OVERALL SIZE	SHIP WT.
LCAA1150DS000	150	UL-142 DOUBLE WALL LUBE CUBE TANK	2'-10" L X 2'-10" W X 4'-1"	620 LBS.
THIS DRAWING AND DESIGN SHOWN HEREIN IS THE PROPERTY OF CONTAINMENT SOLUTIONS. USE OR COPIES THEREOF CANNOT BE MADE WITHOUT WRITTEN CONSENT.				
CUSTOMER NAME	APPROVED BY: _____		DATE: _____	

CONTAINMENT SOLUTIONS®

DRAWN BY: J.HARMON	DATE DRAWN: 12-14-15
DWG NUMBER: 5106479	SCALE: 1:24
REV: A	REV BY: DAR DATE: 10-30-17 SHEET: 1 OF 1