

NOTE:
OVERALL SHIPPING DIMENSION: 3'-9" L X 2'-10" W X 4'-2" H

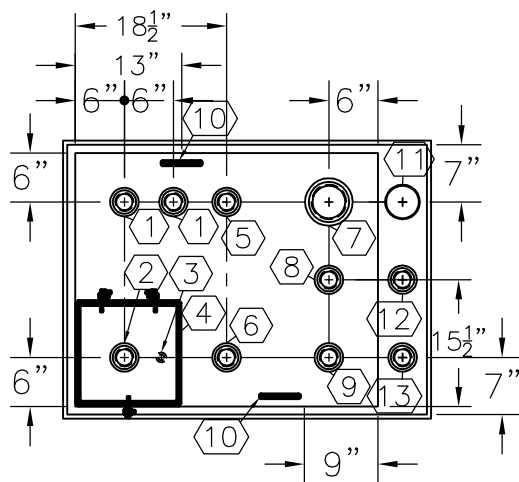

ITEM	SIZE	SUGGESTED FUNCTION
1	2"	SPARE
2	2"	FILL
3	1/2"	DRAIN FOR SPILLBOX
4	7 GAL.	SPILLBOX, DWG."SBB002"
5	2"	PRIMARY TANK WORKING VENT
6	2"	MECHANICAL GAUGE/SPARE
7	4"	PRIMARY TANK EMERGENCY VENT
8	2"	RETURN
9	2"	SUPPLY
10	SMALL	LIFTING LUG
11	4"	SECONDARY CONTAINMENT EMERGENCY VENT
12	2"	SECONDARY MONITOR PORT
13	2"	SECONDARY WORKING VENT

TANK SPECIFICATIONS

VENTING CAPACITY: PRIMARY TANK - 42,100 CUBIC FEET PER HOUR
 SECONDARY TANK - 52,700 CUBIC FEET PER HOUR
 MATERIAL: PRIMARY TANK - 10 GA.
 SECONDARY TANK - 10 GA.

TOP VIEW

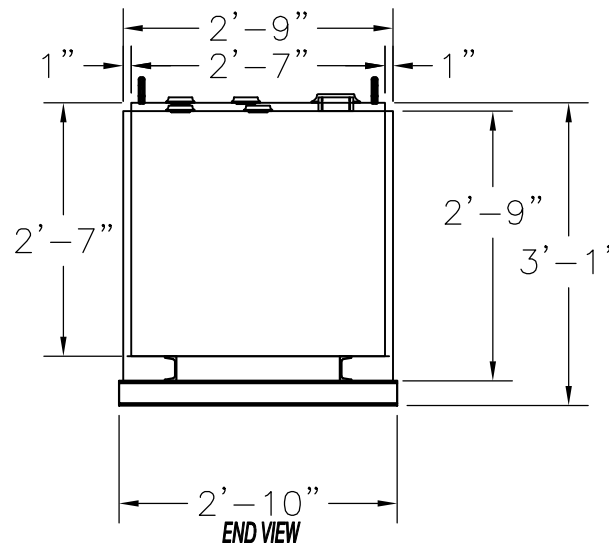
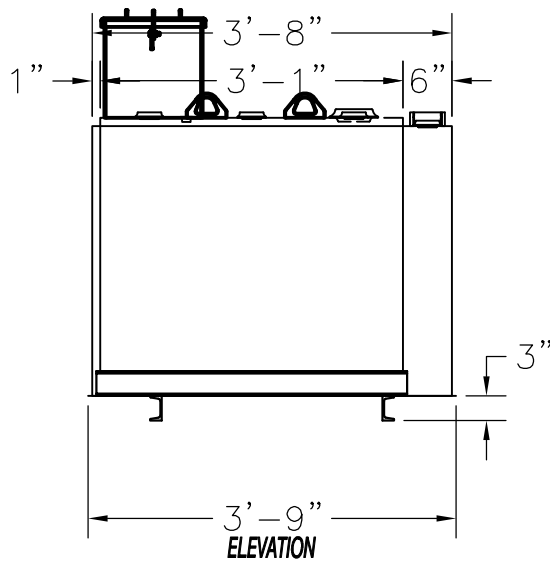

PRODUCT CODE	GALLONS	DESCRIPTION	OVERALL SIZE	SHIP WT.
GCAA1150D8500	150	UL-142 DOUBLE WALL GEN CUBE TANK W/SPILLBOX	3'-9" L X 2'-10" W X 3'-1" H	675 LBS.

THIS DRAWING AND DESIGN SHOWN HEREIN IS THE PROPERTY OF CONTAINMENT SOLUTIONS. USE OR COPIES THEREOF CANNOT BE MADE WITHOUT WRITTEN CONSENT.

CUSTOMER NAME _____ **APPROVED** BY: _____ DATE: _____

CONTAINMENT SOLUTIONS®

DRAWN BY: D. ROVANG	DATE DRAWN: 07-11-16
DWG NUMBER: 5106730	SCALE: 1:24
REV:A	REV BY: DAR
DATE: 01-24-18	SHEET: 1 OF 1