

NOTE:
OVERALL SHIPPING DIMENSION: 3'-9" L X 2'-10" W X 3'-4" H

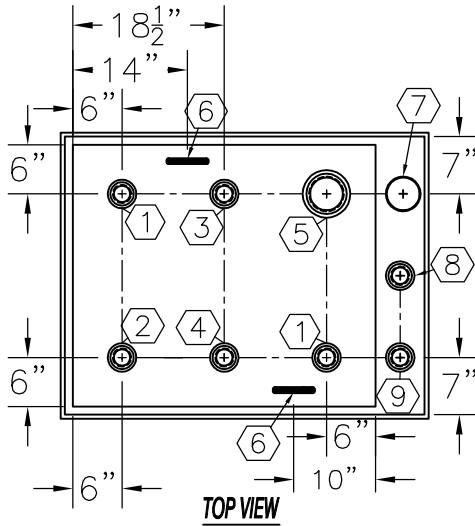

ITEM	SIZE	SUGGESTED FUNCTION
1	2"	SPARE
2	2"	FILL
3	2"	PRIMARY TANK WORKING VENT
4	2"	MECHANICAL GAUGE/ SPARE
5	4"	PRIMARY TANK EMERGENCY VENT
6	SMALL	LIFTING LUG
7	4"	SECONDARY CONTAINMENT EMERGENCY VENT
8	2"	SECONDARY MONITOR PORT/ SPARE
9	2"	SECONDARY WORKING VENT

TANK SPECIFICATIONS

VENTING CAPACITY: PRIMARY TANK - 42,100 CUBIC FEET PER HOUR
 SECONDARY TANK - 52,700 CUBIC FEET PER HOUR
 MATERIAL: PRIMARY TANK - 10 GA.
 SECONDARY TANK - 10 GA.

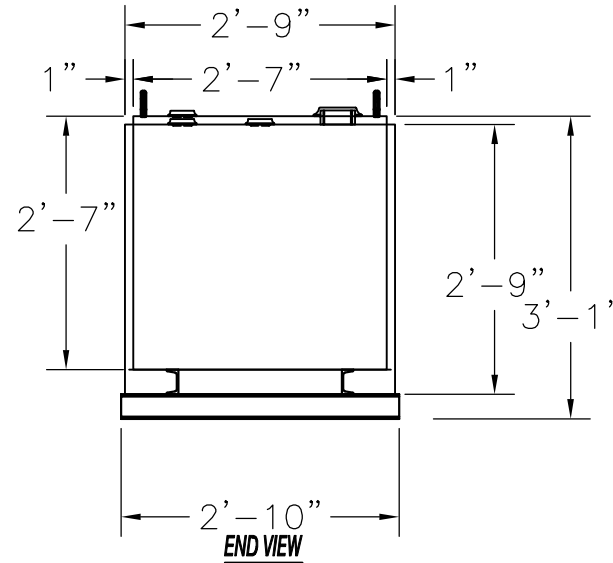
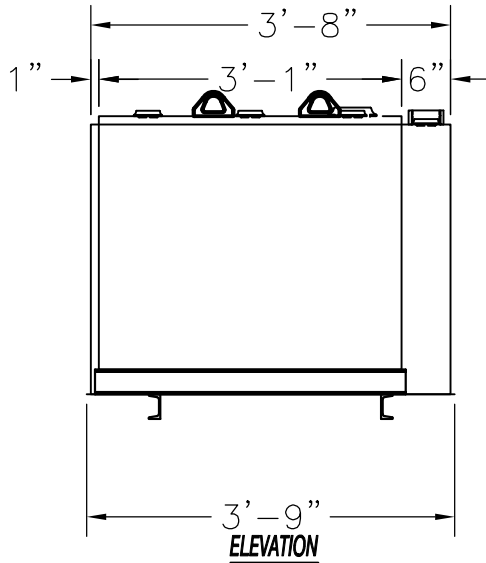

PRODUCT CODE	GALLONS	DESCRIPTION	OVERALL SIZE	SHIP WT.
LCAA1150DS503	150	UL-142 DOUBLE WALL LUBE CUBE TANK	3'-9" L X 2'-10" W X 3'-1"	650 LBS.



THIS DRAWING AND DESIGN SHOWN HEREIN IS THE PROPERTY OF CONTAINMENT SOLUTIONS. USE OR COPIES THEREOF CANNOT BE MADE WITHOUT WRITTEN CONSENT.

CUSTOMER NAME: _____
APPROVED BY: _____ DATE: _____

DRAWN BY: R.OXNER	DATE DRAWN: 05-08-17
DWG NUMBER: 5107113	SCALE: 1:24
REV: A	REV BY: DAR DATE: 10-20-17 SHEET: 1 OF 1