

**NOTE:**  
 OVERALL SHIPPING DIMENSION: 3'-9" L X 2'-10" W X 4'-2" H

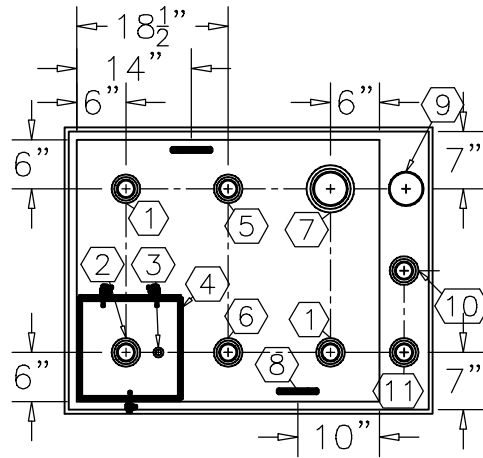

**TOP VIEW**

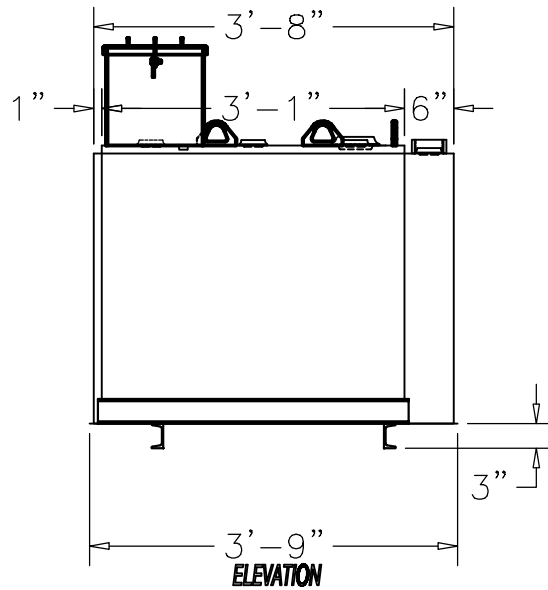

**ELEVATION**

ITEM	SIZE	SUGGESTED FUNCTION
1	2"	SPARE
2	2"	FILL
3	1/2"	DRAIN FOR SPILLBOX
4	7 GAL.	SPILLBOX, DWG."SBB002"
5	2"	PRIMARY TANK WORKING VENT
6	2"	MECHANICAL GAUGE/ SPARE
7	4"	PRIMARY TANK EMERGENCY VENT
8	SMALL	LIFTING LUG
9	4"	SECONDARY CONTAINMENT EMERGENCY VENT
10	2"	SECONDARY MONITOR PORT/ SPARE
11	2"	SECONDARY WORKING VENT

**TANK SPECIFICATIONS**

VENTING CAPACITY: PRIMARY TANK - 42,100 CUBIC FEET PER HOUR

SECONDARY TANK - 52,700 CUBIC FEET PER HOUR

MATERIAL: PRIMARY TANK - 10 GA.

SECONDARY TANK - 10 GA.

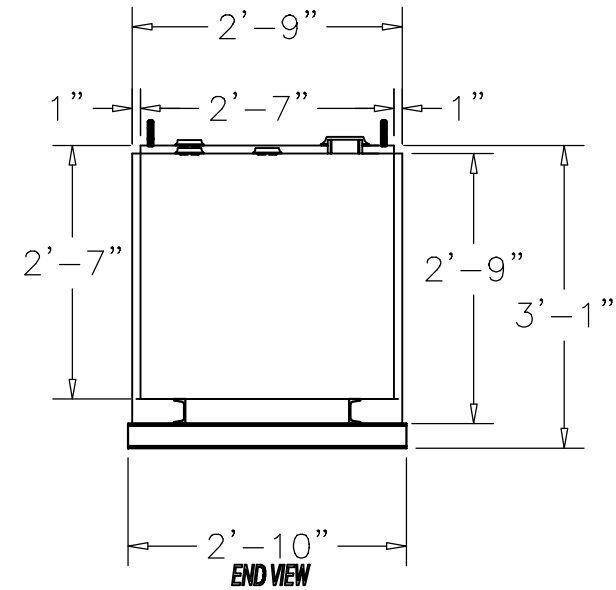

**END VIEW**

PRODUCT CODE	GALLONS	DESCRIPTION	OVERALL SIZE	SHIP WT.
LCAA1150DS001	150	UL-142 DOUBLE WALL LUBE CUBE TANK W/SPILLBOX	3'-9" L X 2'-10" W X 3'-1"	675 LBS.

**CONTAINMENT SOLUTIONS®**

THIS DRAWING AND DESIGN SHOWN HEREIN IS THE PROPERTY OF CONTAINMENT SOLUTIONS. USE OR COPIES THEREOF CANNOT BE MADE WITHOUT WRITTEN CONSENT.

CUSTOMER NAME: \_\_\_\_\_  
**APPROVED** BY: \_\_\_\_\_ DATE: \_\_\_\_\_

DRAWN BY: J.HARMON DATE DRAWN: 12-14-15  
 DWG NUMBER: 5106478 SCALE: 1:24  
 REV: A REV BY: DAR DATE: 10-20-17 SHEET: 1 OF 1