

18" ABOVE LIQUID MANHOLE 12 3/8" TALL

(18) 9/16" DIA. HOLE
ON 21" BOLT CIRCLE

22 1/2" DIA. COVER

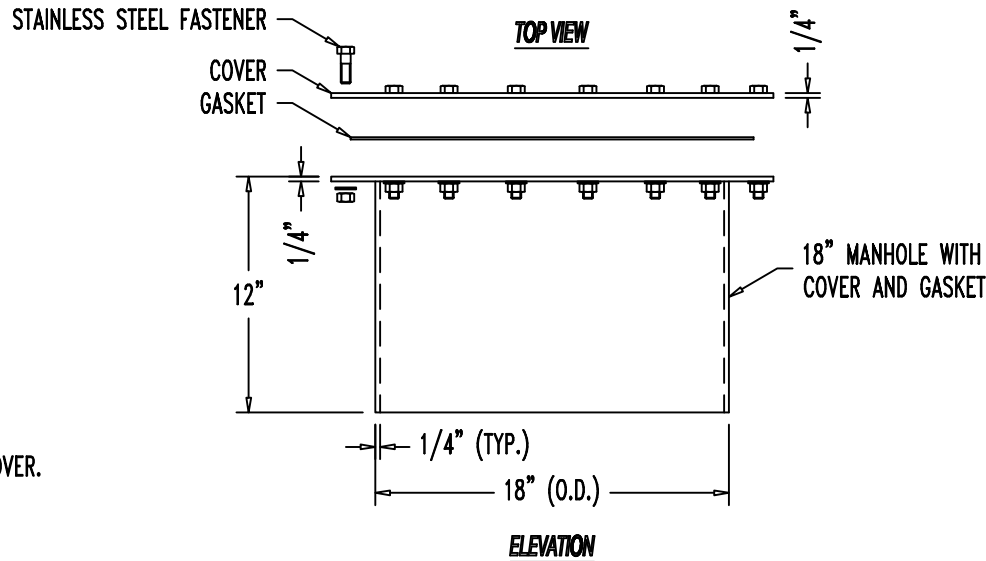

NOTES:

1. MANHOLE ASSEMBLY SHALL BE CARBON STEEL.
2. ALL FASTENERS SHALL BE STAINLESS STEEL.
3. GASKET SHALL BE INSTALLED WITH MANHOLE COVER.
4. GASKET SPECIFICATIONS:
CORK AND NITRILE RUBBER
1/8" THK. X 18" I.D. X 22 1/2" O.D.
5. EXTERIOR COATING SHALL BE THE SAME AS TANK, UNLESS NOTED.

PRODUCT CODE	GALLONS	DESCRIPTION	OVERALL SIZE	SHIP WT.
MHB001		18" U/L ABOVE LIQUID MANWAY	22 1/2" DIA. X 12" H	89 LBS.

THIS DRAWING AND DESIGN SHOWN HEREIN IS THE PROPERTY OF CONTAINMENT SOLUTIONS. USE OR COPIES THEREOF CANNOT BE MADE WITHOUT WRITTEN CONSENT.

CUSTOMER NAME _____

APPROVED BY: _____ DATE: _____

CONTAINMENT SOLUTIONS

DRAWN BY: D. ROVANG DATE DRAWN: 01-01-14

DWG NUMBER: MHB001 SCALE:

REV: REV BY: DATE: SHEET: 1 OF 1