

NOTE:

OVERALL SHIPPING DIMENSION: 13'-9" L X 5'-0" W X 5'-4" H

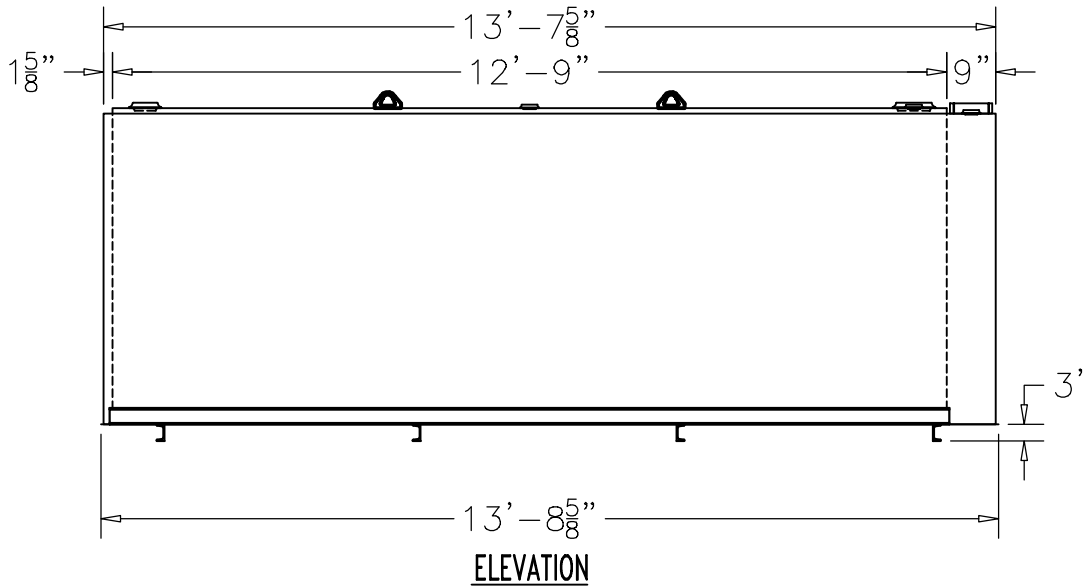
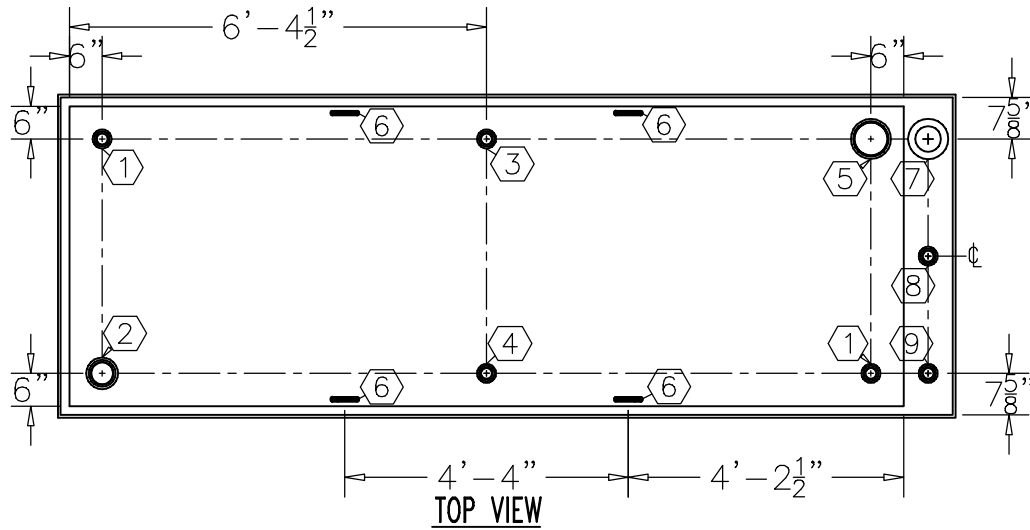

ITEM	SIZE	SUGGESTED FUNCTION
1	2"	SPARE
2	4"	FILL
3	2"	PRIMARY TANK WORKING VENT
4	2"	MECHANICAL GAUGE/SPARE
5	6"	PRIMARY TANK EMERGENCY VENT
6	SMALL	LIFTING LUG
7	6"	SECONDARY CONTAINMENT EMERGENCY VENT
8	2"	SECONDARY MONITOR PORT
9	2"	SECONDARY WORKING VENT

TANK SPECIFICATIONS

VENTING CAPACITY: PRIMARY TANK - 239,000 CUBIC FEET PER HOUR
 SECONDARY TANK - 239,000 CUBIC FEET PER HOUR
 MATERIAL: PRIMARY TANK - 3/16"
 SECONDARY TANK - 10 GA.

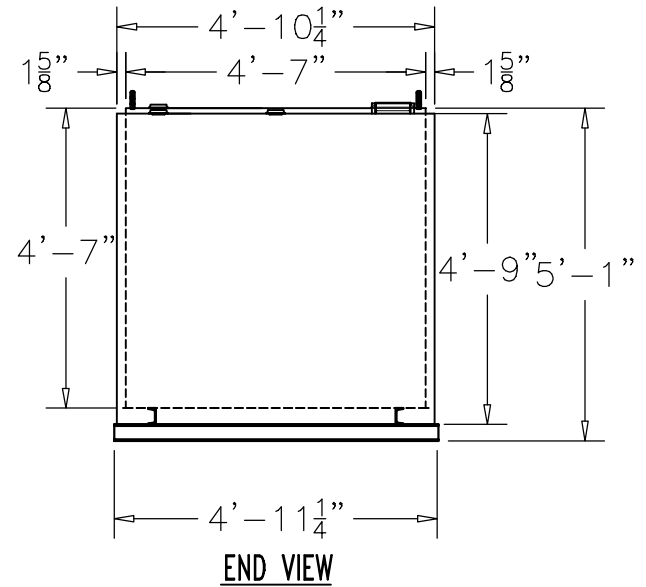

PRODUCT CODE	GALLONS	DESCRIPTION	OVERALL SIZE	SHIP WT.
LCAA102MDS000	2,000	UL-142 DOUBLE WALL LUBE CUBE TANK	13'-9" L X 5'-0" W X 5'-1" H	3,800 LBS.

THIS DRAWING AND DESIGN SHOWN HEREIN IS THE PROPERTY OF CONTAINMENT SOLUTIONS. USE OR COPIES THEREOF CANNOT BE MADE WITHOUT WRITTEN CONSENT.

CUSTOMER NAME: _____
 APPROVED BY: _____ DATE: _____



DRAWN BY: D. ROVANG DATE DRAWN: 01-01-14
 DWG NUMBER: 5100102 SCALE: 1:36
 REV: _____ REV BY: _____ DATE: _____ SHEET: 1 OF 1