

**NOTE:**

OVERALL SHIPPING DIMENSION: 17'-0" L X 5'-0" W X 5'-4" H

ITEM	SIZE	SUGGESTED FUNCTION
1	2"	SPARE
2	4"	FILL
3	2"	PRIMARY TANK WORKING VENT
4	2"	MECHANICAL GAUGE/SPARE
5	6"	PRIMARY TANK EMERGENCY VENT
6	SMALL	LIFTING LUG
7	6"	SECONDARY CONTAINMENT EMERGENCY VENT
8	2"	SECONDARY MONITOR PORT
9	2"	SECONDARY WORKING VENT

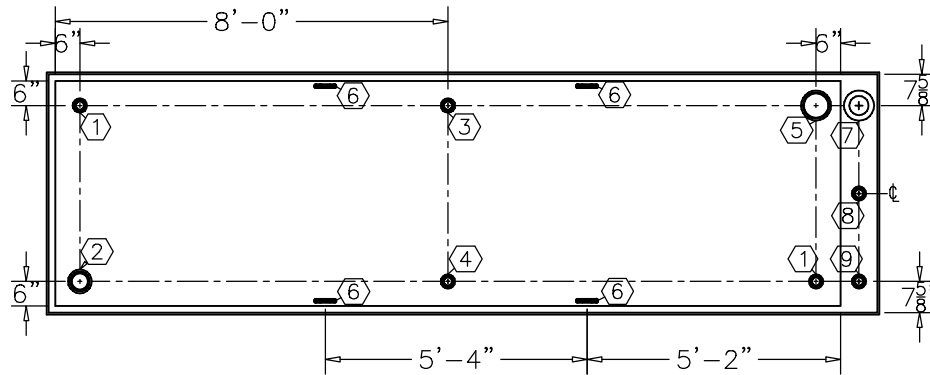

**TOP VIEW**

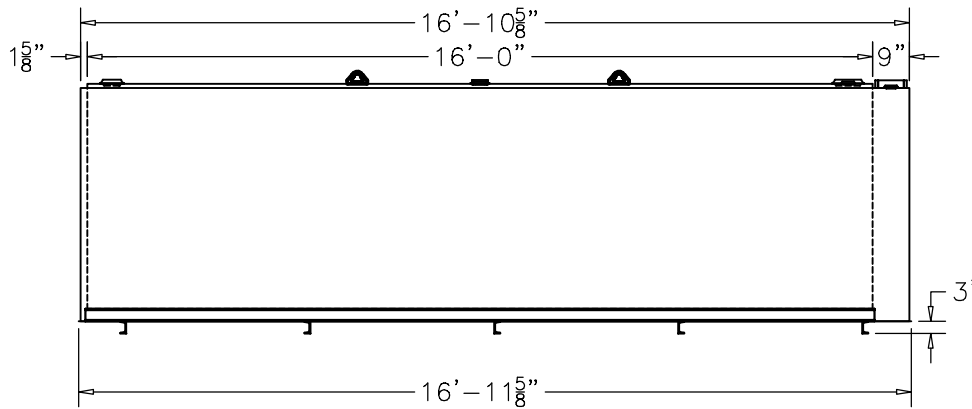

**ELEVATION**

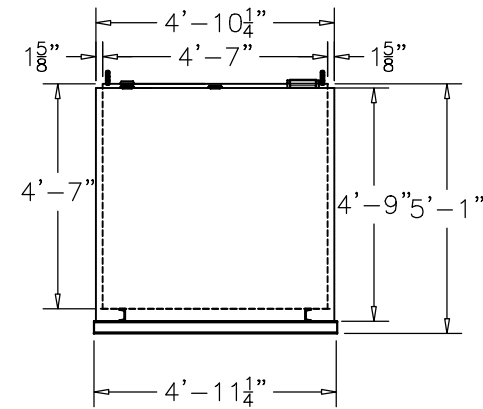

**END VIEW**

**TANK SPECIFICATIONS**

VENTING CAPACITY: PRIMARY TANK - 265,000 CUBIC FEET PER HOUR

SECONDARY TANK - 265,000 CUBIC FEET PER HOUR

MATERIAL: PRIMARY TANK - 3/16"

SECONDARY TANK - 10 GA.

PRODUCT CODE	GALLONS	DESCRIPTION	OVERALL SIZE	SHIP WT.
LCAA125CDS000	2,500	UL-142 DOUBLE WALL LUBE CUBE TANK	17'-0" L X 5'-0" W X 5'-1" H	4,500 LBS.

**CONTAINMENT SOLUTIONS**

THIS DRAWING AND DESIGN SHOWN HEREIN IS THE PROPERTY OF CONTAINMENT SOLUTIONS. USE OR COPIES THEREOF CANNOT BE MADE WITHOUT WRITTEN CONSENT.

CUSTOMER NAME: \_\_\_\_\_

**APPROVED** BY: \_\_\_\_\_ DATE: \_\_\_\_\_

DRAWN BY: D. ROVANG	DATE DRAWN: 01-01-14
DWG NUMBER: 5100103	SCALE: 1:48
REV: _____	REV BY: _____
DATE: _____	SHEET: 1 OF 1