

NOTE:

OVERALL SHIPPING DIMENSION: 17'-0" L X 5'-0" W X 6'-2" H

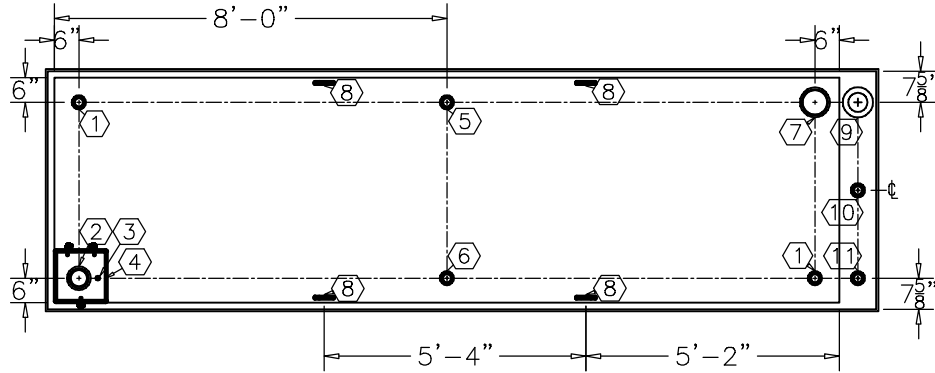

TOP VIEW

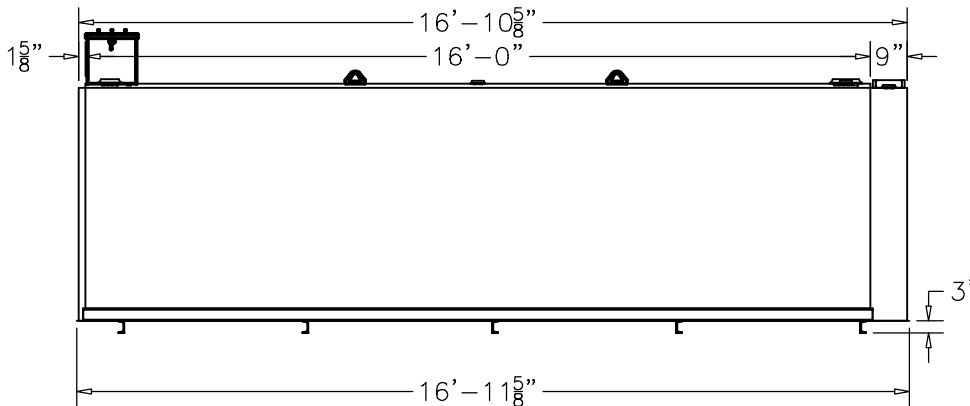

ELEVATION

ITEM	SIZE	SUGGESTED FUNCTION
1	2"	SPARE
2	4"	FILL
3	1/2"	DRAIN FOR SPILLBOX
4	7 GAL.	SPILLBOX, DWG."SBB002"
5	2"	PRIMARY TANK WORKING VENT
6	2"	MECHANICAL GAUGE/ SPARE
7	6"	PRIMARY TANK EMERGENCY VENT
8	SMALL	LIFTING LUG
9	6"	SECONDARY CONTAINMENT EMERGENCY VENT
10	2"	SECONDARY MONITOR PORT
11	2"	SECONDARY WORKING VENT

TANK SPECIFICATIONS

VENTING CAPACITY: PRIMARY TANK - 265,000 CUBIC FEET PER HOUR

SECONDARY TANK - 265,000 CUBIC FEET PER HOUR

MATERIAL: PRIMARY TANK - 3/16"

SECONDARY TANK - 10 GA.

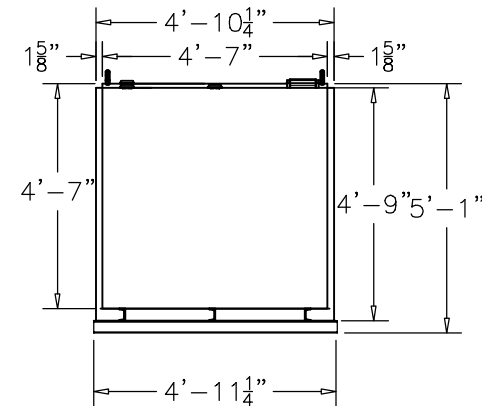

END VIEW

PRODUCT CODE	GALLONS	DESCRIPTION	OVERALL SIZE	SHIP WT.
LCAA125CDS001	2,500	UL-142 DOUBLE WALL LUBE CUBE TANK W/SPILLBOX	17'-0" L X 5'-0" W X 5'-1" H	4,500 LBS.

THIS DRAWING AND DESIGN SHOWN HEREIN IS THE PROPERTY OF CONTAINMENT SOLUTIONS. USE OR COPIES THEREOF CANNOT BE MADE WITHOUT WRITTEN CONSENT.

CUSTOMER NAME: _____ APPROVED BY: _____ DATE: _____



DRAWN BY: D. ROVANG	DATE DRAWN: 01-01-14
DWG NUMBER: 5100122	SCALE: 1:48
REV: _____	REV BY: _____
DATE: _____	SHEET: 1 OF 1