

ITEM	SIZE	SUGGESTED FUNCTION
1	2"	SPARE
2	2"	FILL
3	2"	PRIMARY TANK WORKING VENT
4	2"	MECHANICAL GAUGE/SPARE
5	4"	PRIMARY TANK EMERGENCY VENT
6	SMALL	LIFTING LUG
7	4"	SECONDARY CONTAINMENT EMERGENCY VENT
8	2"	SECONDARY MONITOR PORT
9	2"	SECONDARY WORKING VENT

TANK SPECIFICATIONS
VENTING CAPACITY: PRIMARY TANK - 52,700 CUBIC FEET PER HOUR
SECONDARY TANK - 63,200 CUBIC FEET PER HOUR
MATERIAL: PRIMARY TANK - 10 GA.
SECONDARY TANK - 10 GA.

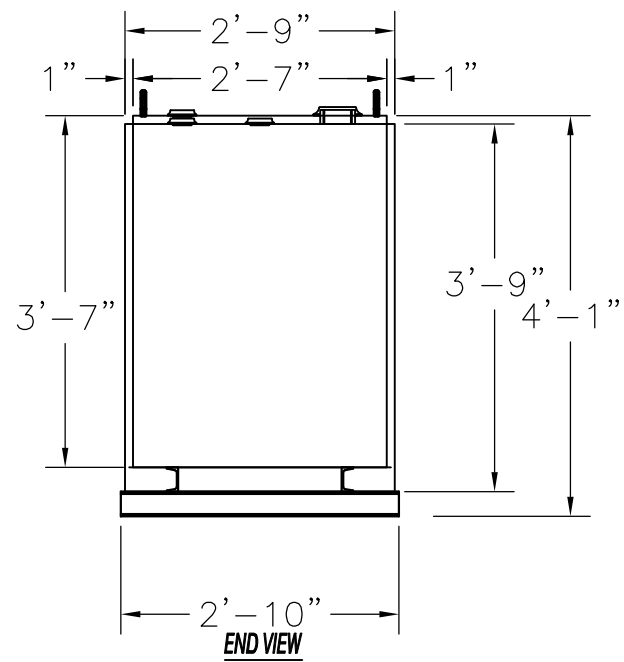
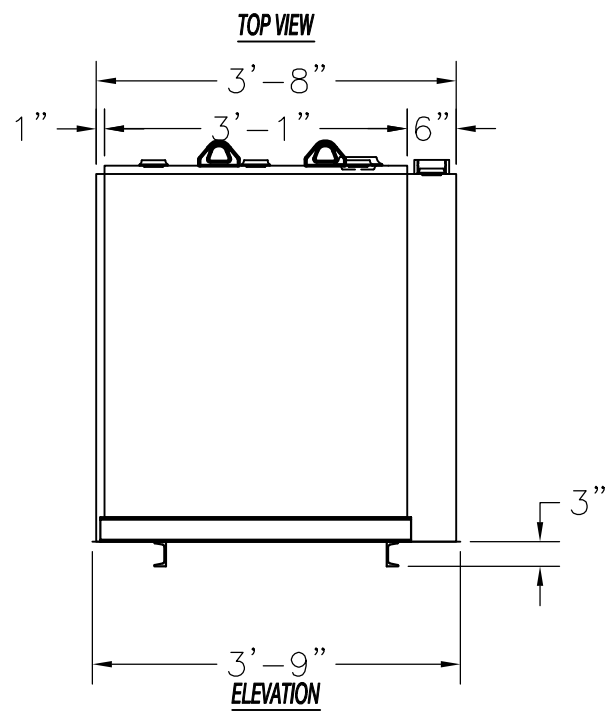

PRODUCT CODE	GALLONS	DESCRIPTION	OVERALL SIZE	SHIP WT.
LCAA1210D8513	210	UL-142 DOUBLE WALL LUBE CUBE TANK	3'-9" L X 2'-10" W X 4'-1" H	800 LBS.
THIS DRAWING AND DESIGN SHOWN HEREIN IS THE PROPERTY OF CONTAINMENT SOLUTIONS. USE OR COPIES THEREOF CANNOT BE MADE WITHOUT WRITTEN CONSENT.				
CUSTOMER NAME	APPROVED BY: _____		DATE: _____	

CONTAINMENT SOLUTIONS®

DRAWN BY: D. ROVANG	DATE DRAWN: 05-11-17
DWG NUMBER: 5107124	SCALE: 1:24
REV: _____	REV BY: _____
DATE: _____	SHEET: 1 OF 1