

ITEM	SIZE	SUGGESTED FUNCTION
1	2"	SPARE
2	2"	FILL
3	2"	PRIMARY TANK WORKING VENT
4	2"	MECHANICAL GAUGE/SPARE
5	4"	PRIMARY TANK EMERGENCY VENT
6	SMALL	LIFTING LUG
7	4"	SECONDARY CONTAINMENT EMERGENCY VENT
8	2"	SECONDARY MONITOR PORT
9	2"	SECONDARY WORKING VENT

**TANK SPECIFICATIONS**

VENTING CAPACITY: PRIMARY TANK - 31,600 CUBIC FEET PER HOUR  
 SECONDARY TANK - 63,200 CUBIC FEET PER HOUR  
 MATERIAL: PRIMARY TANK - 10 GA.  
 SECONDARY TANK - 10 GA.

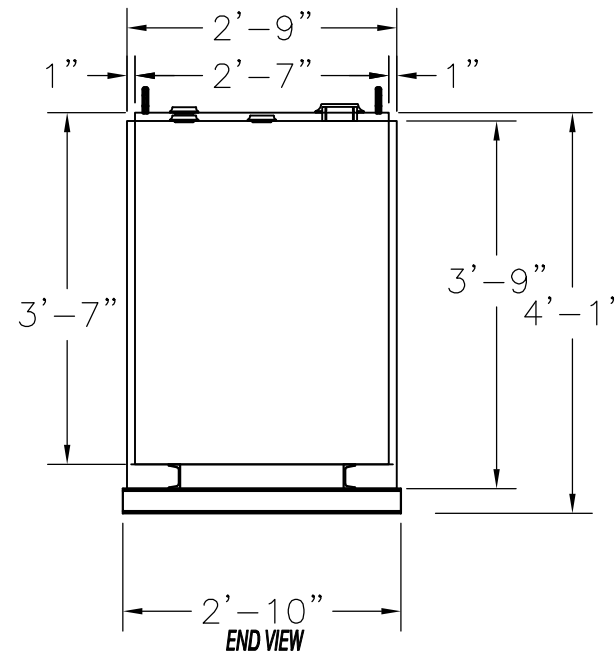
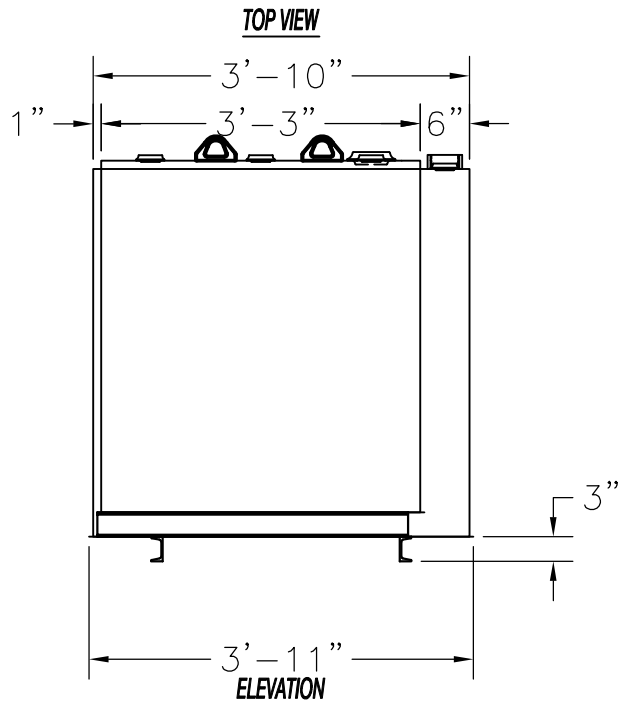

PRODUCT CODE	GALLONS	DESCRIPTION	OVERALL SIZE	SHIP WT.
LCAA1225DS000	225	UL-142 DOUBLE WALL LUBE CUBE TANK	3'-11" L X 2'-10" W X 4'-1" H	800 LBS.

**CONTAINMENT SOLUTIONS®**

THIS DRAWING AND DESIGN SHOWN HEREIN IS THE PROPERTY OF CONTAINMENT SOLUTIONS. USE OR COPIES THEREOF CANNOT BE MADE WITHOUT WRITTEN CONSENT.

CUSTOMER NAME: \_\_\_\_\_  
**APPROVED** BY: \_\_\_\_\_ DATE: \_\_\_\_\_

DRAWN BY: D. ROVANG DATE DRAWN: 10-18-17  
 DWG NUMBER: 5107394 SCALE: 1:24  
 REV: A REV BY: DAR DATE: 10-23-17 SHEET: 1 OF 1