

ITEM	SIZE	SUGGESTED FUNCTION
1	2"	SPARE
2	2"	FILL
3	2"	PRIMARY TANK WORKING VENT
4	2"	MECHANICAL GAUGE/ SPARE
5	4"	PRIMARY TANK EMERGENCY VENT
6	SMALL	LIFTING LUG
7	4"	SECONDARY CONTAINMENT EMERGENCY VENT
8	2"	SECONDARY MONITOR PORT/ SPARE
9	2"	SECONDARY WORKING VENT

TANK SPECIFICATIONS

VENTING CAPACITY: PRIMARY TANK - 63,200 CUBIC FEET PER HOUR

SECONDARY TANK - 73,700 CUBIC FEET PER HOUR

MATERIAL: PRIMARY TANK - 10 GA.

SECONDARY TANK - 10 GA.

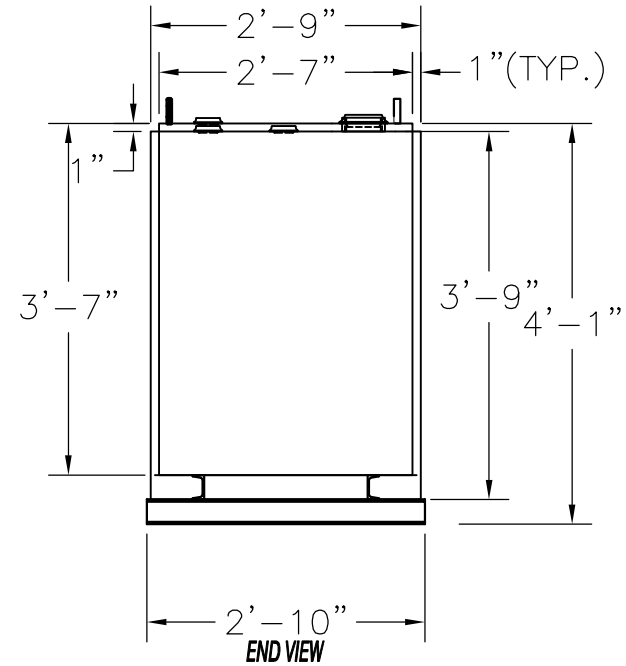
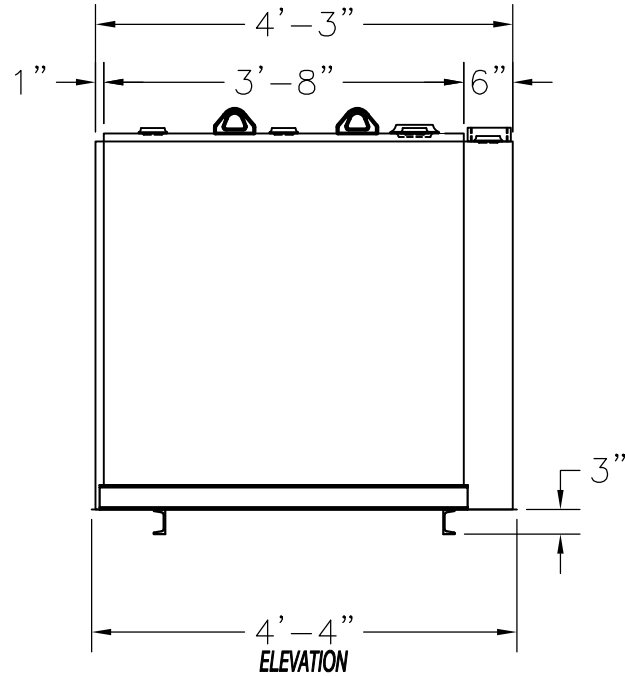

PRODUCT CODE	GALLONS	DESCRIPTION	OVERALL SIZE	SHIP WT.
LCAA1250D8516	250	U/L-142 DOUBLE WALL LUBE CUBE TANK	4'-4" L X 2'-10" W X 4'-1" H	850 LBS.

THIS DRAWING AND DESIGN SHOWN HEREIN IS THE PROPERTY OF CONTAINMENT SOLUTIONS. USE OR COPIES THEREOF CANNOT BE MADE WITHOUT WRITTEN CONSENT.

CUSTOMER NAME: _____
APPROVED BY: _____ DATE: _____

CONTAINMENT SOLUTIONS®

DRAWN BY: D. ROVANG DATE DRAWN: 01-30-08
 DWG NUMBER: 5103114 SCALE: 1:24
 REV: B REV BY: DAR DATE: 10-23-17 SHEET: 1 OF 1