

ITEM	SIZE	SUGGESTED FUNCTION
1	2"	SPARE
2	2"	FILL
3	1/2"	DRAIN FOR SPILLBOX
4	7 GAL.	SPILLBOX, DWG."SBB002"
5	2"	PRIMARY TANK WORKING VENT
6	2"	MECHANICAL GAUGE/ SPARE
7	4"	PRIMARY TANK EMERGENCY VENT
8	SMALL	LIFTING LUG
9	4"	SECONDARY CONTAINMENT EMERGENCY VENT
10	2"	SECONDARY MONITOR PORT/ SPARE
11	2"	SECONDARY WORKING VENT

TANK SPECIFICATIONS

VENTING CAPACITY: PRIMARY TANK - 63,200 CUBIC FEET PER HOUR
 SECONDARY TANK - 73,700 CUBIC FEET PER HOUR
 MATERIAL: PRIMARY TANK - 10 GA.
 SECONDARY TANK - 10 GA.

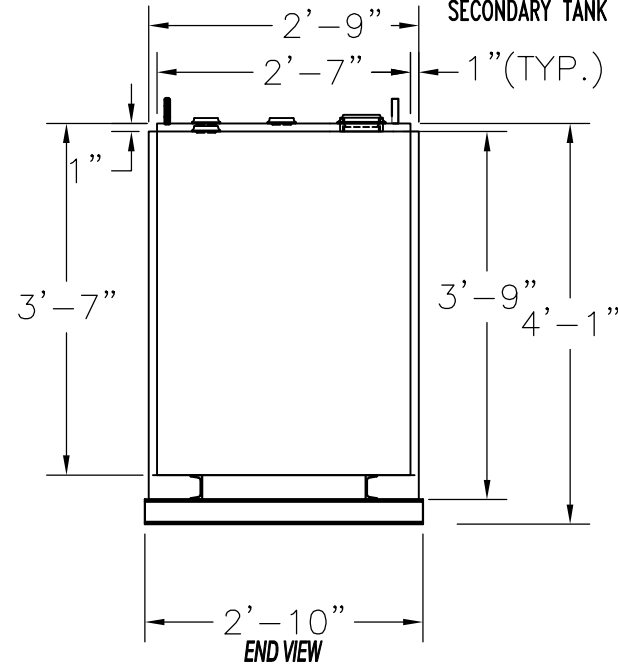
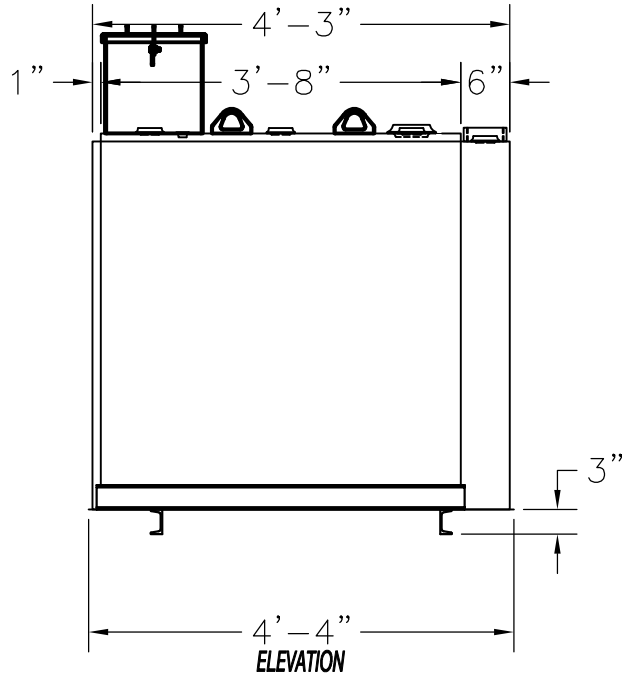

PRODUCT CODE	GALLONS	DESCRIPTION	OVERALL SIZE	SHIP WT.
LCAA1250D8529	250	U/L-142 DOUBLE WALL LUBE CUBE TANK W/SPILLBOX	4'-4" L X 2'-10" W X 4'-1" H	875 LBS.

THIS DRAWING AND DESIGN SHOWN HEREIN IS THE PROPERTY OF CONTAINMENT SOLUTIONS. USE OR COPIES THEREOF CANNOT BE MADE WITHOUT WRITTEN CONSENT.

CUSTOMER NAME: _____
APPROVED BY: _____ DATE: _____

CONTAINMENT SOLUTIONS®

DRAWN BY: D. ROVANG DATE DRAWN: 12-06-10
 DWG NUMBER: 5104341 SCALE: 1:24
 REV: B REV BY: DAR DATE: 10-23-17 SHEET: 1 OF 1