

NOTE:  
 OVERALL SHIPPING DIMENSION: 20'-5" L X 5'-0" W X 6'-2" H

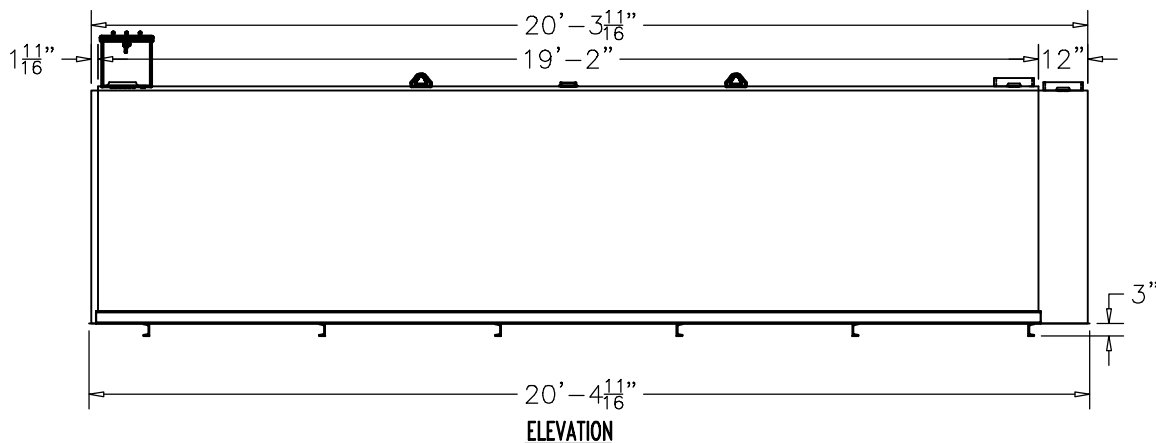
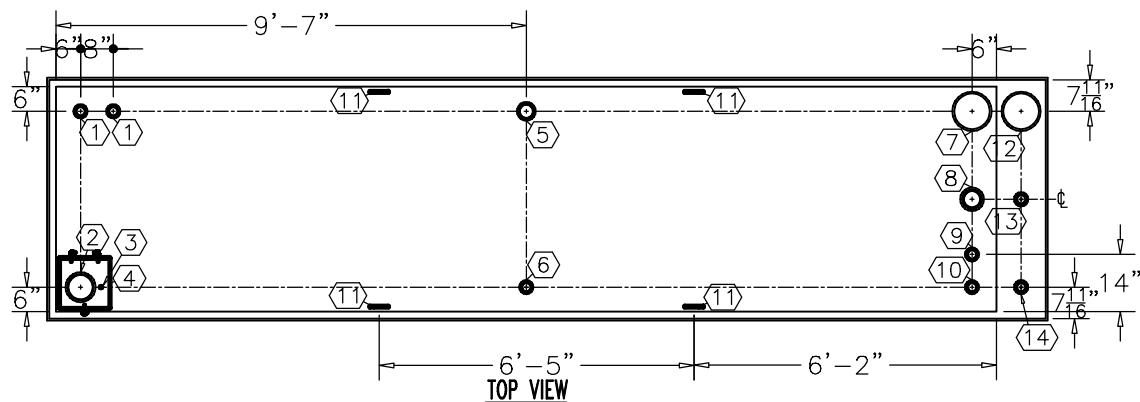

ITEM	SIZE	SUGGESTED FUNCTION
1	2"	SPARE
2	6"	FILL
3	1/2"	DRAIN FOR SPILLBOX
4	7 GAL.	SPILLBOX, DWG."SBB002"
5	3"	PRIMARY TANK WORKING VENT
6	2"	MECHANICAL GAUGE/ SPARE
7	8"	PRIMARY TANK EMERGENCY VENT
8	4"	SPARE
9	2"	RETURN
10	2"	SUPPLY
11	SMALL	LIFTING LUG
12	8"	SECONDARY CONTAINMENT EMERGENCY VENT
13	2"	SECONDARY MONITOR PORT
14	2"	SECONDARY WORKING VENT

**TANK SPECIFICATIONS**

VENTING CAPACITY: PRIMARY TANK - 288,000 CUBIC FEET PER HOUR  
 SECONDARY TANK - 288,000 CUBIC FEET PER HOUR  
 MATERIAL: PRIMARY TANK - 3/16"  
 SECONDARY TANK - 3/16"

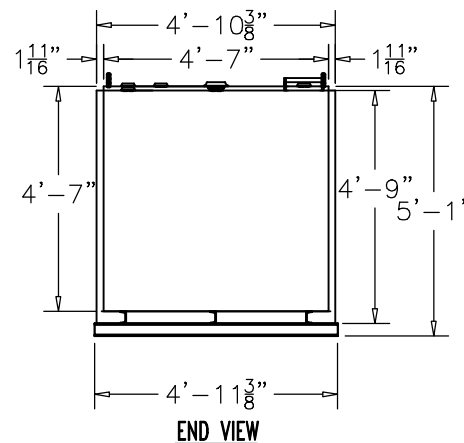

PRODUCT CODE	GALLONS	DESCRIPTION	OVERALL SIZE	SHIP WT.
GCAA103MDS001	3,000	UL-142 DOUBLE WALL GEN CUBE TANK W/SPILLBOX	20'-5" L X 5'-0" W X 5'-1" H	6,650 LBS.

THIS DRAWING AND DESIGN SHOWN HEREIN IS THE PROPERTY OF CONTAINMENT SOLUTIONS. USE OR COPIES THEREOF CANNOT BE MADE WITHOUT WRITTEN CONSENT.

CUSTOMER NAME: \_\_\_\_\_  
 APPROVED BY: \_\_\_\_\_ DATE: \_\_\_\_\_

**CONTAINMENT SOLUTIONS**

DRAWN BY: D. ROVANG      DATE DRAWN: 01-01-14  
 DWG NUMBER: 5104011      SCALE: 1:48  
 REV:    REV BY:    DATE:    SHEET: 1 OF 1