

NOTE:
 OVERALL SHIPPING DIMENSION: 11'-8" L X 8'-6" W X 8'-5" H

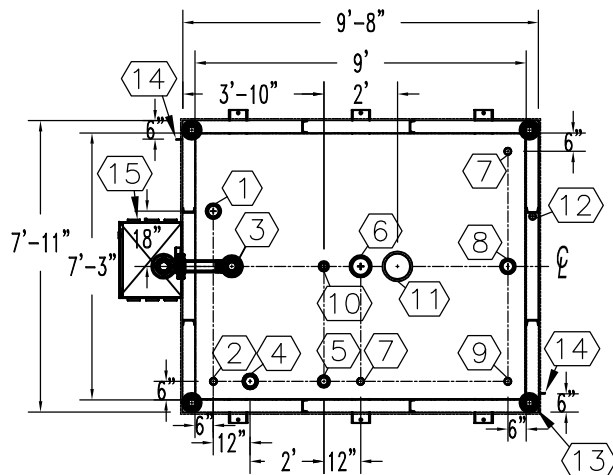

ITEM	SIZE	SUGGESTED FUNCTION
1	4"	PHASE 1 VAPOR RECOVERY/SPARE
2	2"	MECHANICAL GAUGE
3	6"	FILL
4	4"	ELECTRONIC LEVEL GAUGE
5	3"	PRIMARY WORKING VENT
6	6"	PRIMARY TANK EMERGENCY VENT
7	2"	SPARE
8	4"	SUBMERSIBLE PUMP
9	2"	SUCTION PUMP/SPARE
10	2"	SECONDARY WORKING VENT
11	8"	SECONDARY CONTAINMENT EMERGENCY VENT
12	2"	SECONDARY MONITOR PIPE
13	4"	FIRE RATED MATERIAL FILL
14	2" X 2"	GROUND CLIP, DWG."MCB004"
15	3" PIPE	MORRISON REMOTE FILL BOX, DWG."SBB202"

TANK SPECIFICATIONS

VENTING CAPACITY: PRIMARY TANK - 265,000 CUBIC FEET PER HOUR
 SECONDARY TANK - 288,000 CUBIC FEET PER HOUR

MATERIAL: PRIMARY TANK - 1/4" THICK
 SECONDARY TANK - 3/16" THICK

TOP VIEW

THREADED CONNECTION
 (TYP.) SEE TOP VIEW

2" STD. PIPE FOR
 MONITOR ACCESS

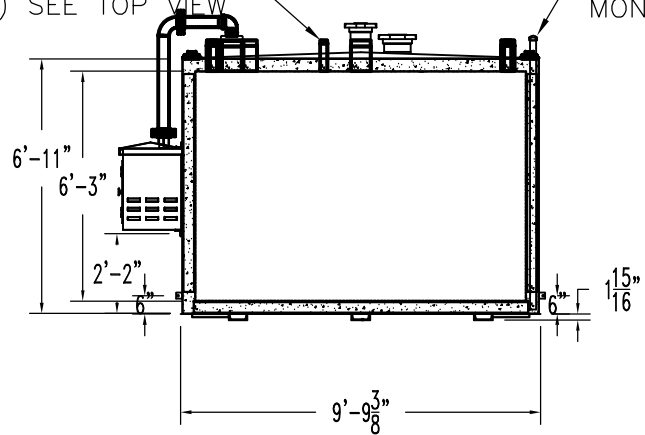

ELEVATION

SEAL WELD ALL
 FITTINGS AND TANK

4" SPACE BETWEEN
 INNER & OUTER TANKS
 FILLED WITH LIGHT WEIGHT
 FIRE-RATED MATERIAL

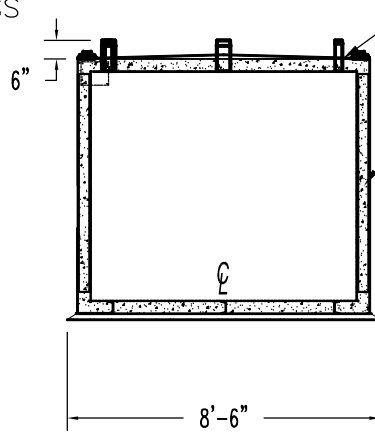

END VIEW

PRODUCT CODE	GALLONS	DESCRIPTION	OVERALL SIZE	SHIP WT.
V4AA103MVS548	3,000	U/L-2085 ABOVE GROUND VAULT TANK	9'-8" L X 7'-11" W X 7'-1" H	16,200 LBS.



THIS DRAWING AND DESIGN SHOWN HEREIN IS THE PROPERTY OF CONTAINMENT SOLUTIONS. USE OR COPIES THEREOF CANNOT BE MADE WITHOUT WRITTEN CONSENT.

CUSTOMER NAME: _____
APPROVED BY: _____ DATE: _____

DRAWN BY: D. ROVANG DATE DRAWN: 09-01-11
 DWG NUMBER: 5104653 SCALE: 1:64
 REV:C REV BY: DAR DATE: 01-01-14 SHEET: 1 OF 1