

**NOTE:**  
 OVERALL SHIPPING DIMENSION: 3'-10" L X 3'-10" W X 5'-2" H

ITEM	SIZE	SUGGESTED FUNCTION
1	2"	SPARE
2	2"	FILL
3	1/2"	DRAIN FOR SPILLBOX
4	7 GAL.	SPILLBOX, DWG."SBB002"
5	2"	PRIMARY TANK WORKING VENT
6	2"	MECHANICAL GAUGE/SPARE
7	4"	PRIMARY TANK EMERGENCY VENT
8	SMALL	LIFTING LUG
9	4"	SECONDARY CONTAINMENT EMERGENCY VENT
10	2"	SECONDARY MONITOR PORT
11	2"	SECONDARY WORKING VENT

**TANK SPECIFICATIONS**

VENTING CAPACITY: PRIMARY TANK - 63,200 CUBIC FEET PER HOUR  
 SECONDARY TANK - 73,700 CUBIC FEET PER HOUR  
 MATERIAL: PRIMARY TANK - 10 GA.  
 SECONDARY TANK - 10 GA.

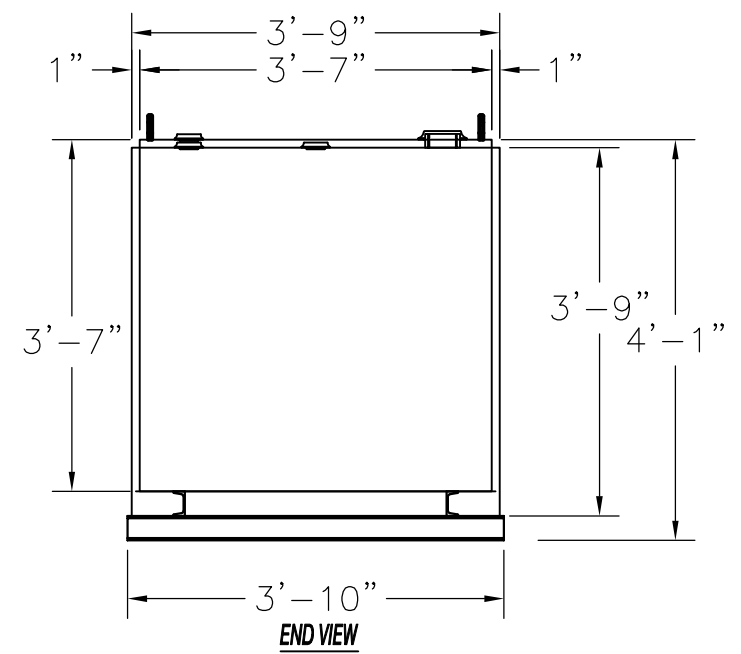
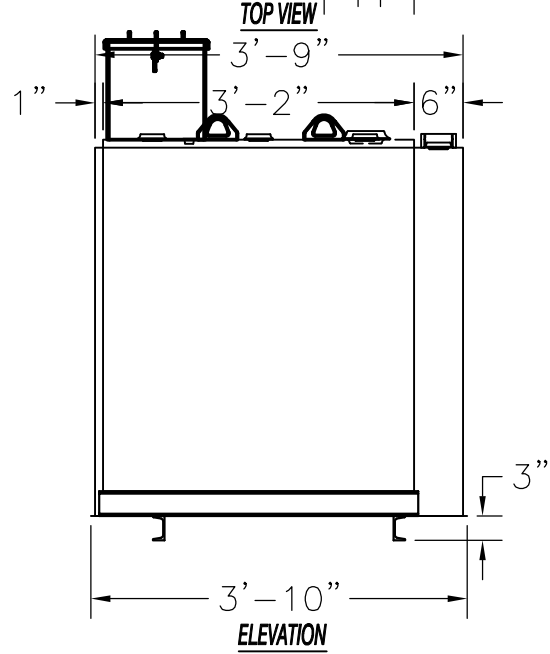

PRODUCT CODE	GALLONS	DESCRIPTION	OVERALL SIZE	SHIP WT.
LCAA1300D8550	300	UL-142 DOUBLE WALL LUBE CUBE TANK W/SPILLBOX	3'-10" L X 3'-10" W X 4'-1" H	975 LBS.
THIS DRAWING AND DESIGN SHOWN HEREIN IS THE PROPERTY OF CONTAINMENT SOLUTIONS. USE OR COPIES THEREOF CANNOT BE MADE WITHOUT WRITTEN CONSENT.				
CUSTOMER NAME		APPROVED BY: _____		DATE: _____

**CONTAINMENT SOLUTIONS®**

DRAWN BY: D. ROVANG      DATE DRAWN: 05-03-17  
 DWG NUMBER: 5107107      SCALE: 1:24  
 REV:A    REV BY: DAR    DATE: 10-23-17    SHEET: 1 OF 1