

8 7 6 5 4 3 2 1

F

E

D

C

B

A

NOTE:

OVERALL SHIPPING DIMENSION: 4'-4" L X 3'-10" W X 4'-4" H

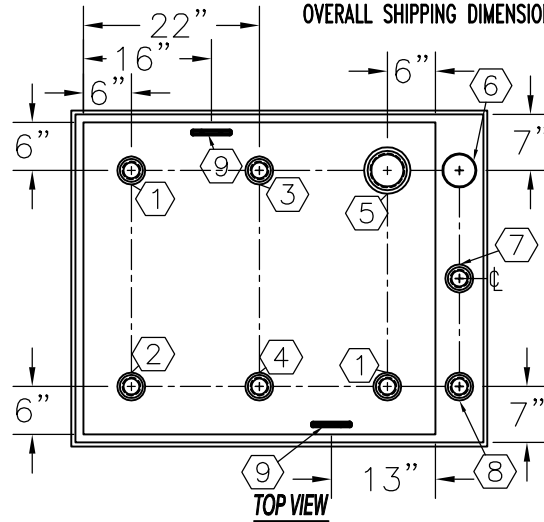

TOP VIEW

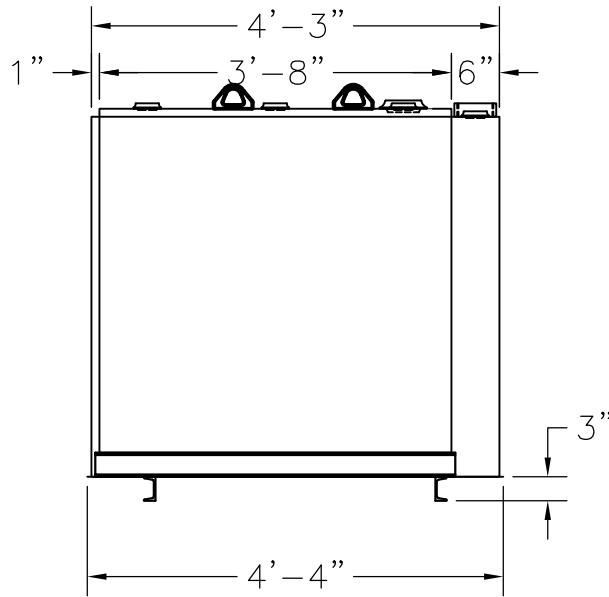

ELEVATION

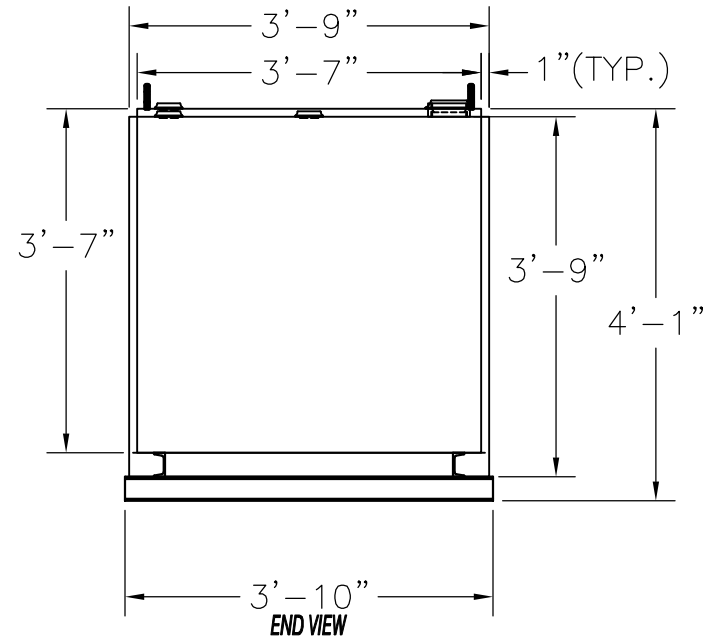

END VIEW

ITEM	SIZE	SUGGESTED FUNCTION
1	2"	SPARE
2	2"	FILL
3	2"	PRIMARY TANK WORKING VENT
4	2"	MECHANICAL GAUGE/ SPARE
5	4"	PRIMARY TANK EMERGENCY VENT
6	4"	SECONDARY CONTAINMENT EMERGENCY VENT
7	2"	SECONDARY MONITOR PORT/ SPARE
8	2"	SECONDARY WORKING VENT
9	SMALL	LIFTING LUG

TANK SPECIFICATIONS

VENTING CAPACITY: PRIMARY TANK - 73,700 CUBIC FEET PER HOUR
 SECONDARY TANK - 94,800 CUBIC FEET PER HOUR

MATERIAL: PRIMARY TANK - 10 GA.
 SECONDARY TANK - 10 GA.

PRODUCT CODE	GALLONS	DESCRIPTION	OVERALL SIZE	SHIP WT.
LCAA1350D8518	350	UL-142 DOUBLE WALL LUBE CUBE TANK	4'-4" L X 3'-10" W X 4'-1" H	950 LBS.

THIS DRAWING AND DESIGN SHOWN HEREIN IS THE PROPERTY OF CONTAINMENT SOLUTIONS. USE OR COPIES THEREOF CANNOT BE MADE WITHOUT WRITTEN CONSENT.

CUSTOMER NAME	APPROVED BY: _____	DATE: _____
---------------	---------------------------	-------------

CONTAINMENT SOLUTIONS®

DRAWN BY: J.HARMON	DATE DRAWN: 09-10-14
DWG NUMBER: 5105878	SCALE: 1:24
REV: A	REV BY: DAR
DATE: 02-27-17	SHEET: 1 OF 1

8 7 6 5 4 3 2 1