

NOTE:
 OVERALL SHIPPING DIMENSION: 4'-4" L X 3'-10" W X 5'-2" H

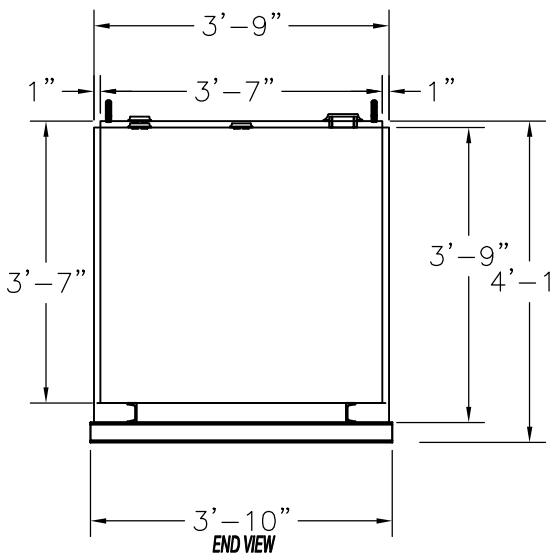
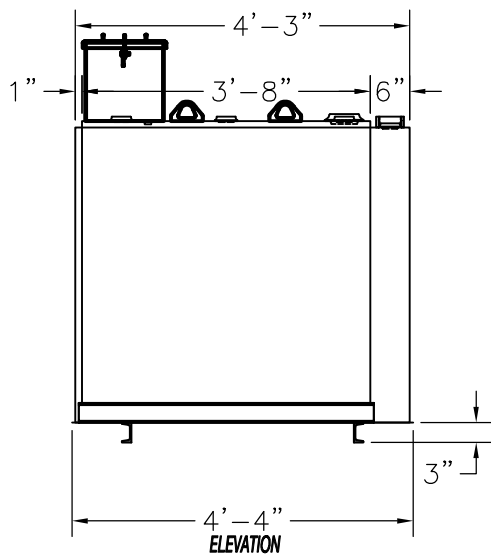
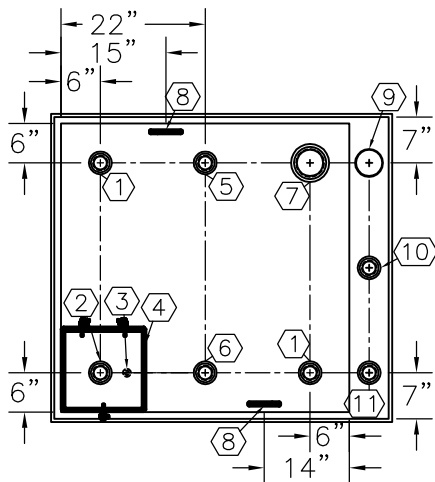

| ITEM | SIZE | SUGGESTED FUNCTION |
|------|--------|--------------------------------------|
| 1 | 2" | SPARE |
| 2 | 2" | FILL |
| 3 | 1/2" | DRAIN FOR SPILLBOX |
| 4 | 7 GAL. | SPILLBOX, DWG."SBB002" |
| 5 | 2" | PRIMARY TANK WORKING VENT |
| 6 | 2" | MECHANICAL GAUGE/ SPARE |
| 7 | 4" | PRIMARY TANK EMERGENCY VENT |
| 8 | SMALL | LIFTING LUG |
| 9 | 4" | SECONDARY CONTAINMENT EMERGENCY VENT |
| 10 | 2" | SECONDARY MONITOR PORT/ SPARE |
| 11 | 2" | SECONDARY WORKING VENT |

TANK SPECIFICATIONS

VENTING CAPACITY: PRIMARY TANK - 73,700 CUBIC FEET PER HOUR

SECONDARY TANK - 84,200 CUBIC FEET PER HOUR

MATERIAL: PRIMARY TANK - 10 GA.

SECONDARY TANK - 10 GA.

PRODUCT CODE

GALLONS

DESCRIPTION

OVERALL SIZE

SHIP WT.

LCAA1350DS001

350

UL-142 DOUBLE WALL LUBE CUBE TANK W/SPILLBOX

4'-4" L X 3'-10" W X 4'-1"

1,050 LBS.

THIS DRAWING AND DESIGN SHOWN HEREIN IS THE PROPERTY OF CONTAINMENT SOLUTIONS. USE OR COPIES THEREOF CANNOT BE MADE WITHOUT WRITTEN CONSENT.

CUSTOMER NAME

APPROVED BY: _____

DATE: _____

CONTAINMENT SOLUTIONS®

DRAWN BY: J.HARMON

DATE DRAWN: 02-01-15

DWG NUMBER: 5106685

SCALE: 1:24

REV:A

REV BY: DAR

DATE: 10-20-17 | SHEET: 1 OF 1