

NOTE:  
 OVERALL SHIPPING DIMENSION: 4'-7" L X 3'-10" W X 4'-4" H

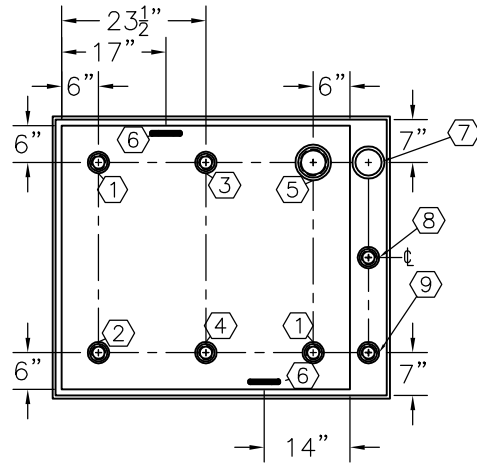

TOP VIEW

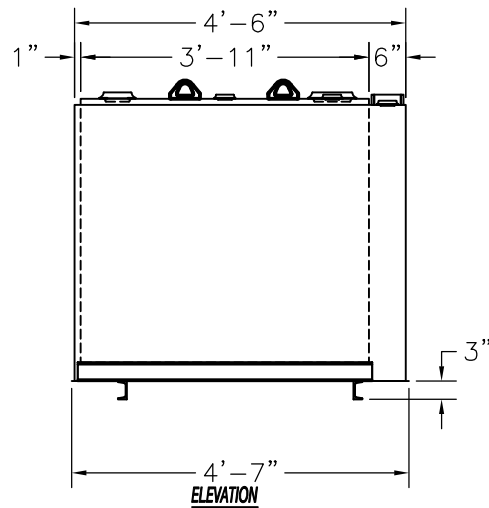

ELEVATION

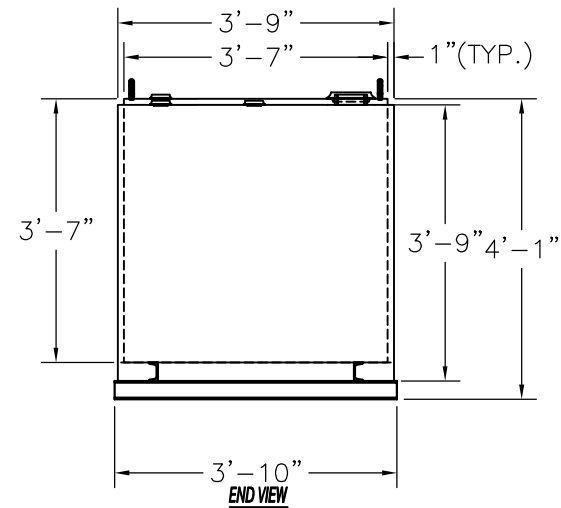

END VIEW

ITEM	SIZE	SUGGESTED FUNCTION
1	2"	SPARE
2	2"	FILL
3	2"	PRIMARY TANK WORKING VENT
4	2"	MECHANICAL GAUGE/SPARE
5	4"	PRIMARY TANK EMERGENCY VENT
6	SMALL	LIFTING LUG
7	4"	SECONDARY CONTAINMENT EMERGENCY VENT
8	2"	SECONDARY MONITOR PORT
9	2"	SECONDARY WORKING VENT

TANK SPECIFICATIONS

VENTING CAPACITY: PRIMARY TANK - 73,700 CUBIC FEET PER HOUR  
 SECONDARY TANK - 84,200 CUBIC FEET PER HOUR  
 MATERIAL: PRIMARY TANK - 10 GA.  
 SECONDARY TANK - 10 GA.

PRODUCT CODE	GALLONS	DESCRIPTION	OVERALL SIZE	SHIP WT.
LCAA1375D8503	375	UL-142 DOUBLE WALL LUBE CUBE TANK	4'-7" L X 3'-10" W X 4'-1" H	1,050 LBS.

THIS DRAWING AND DESIGN SHOWN HEREIN IS THE PROPERTY OF CONTAINMENT SOLUTIONS. USE OR COPIES THEREOF CANNOT BE MADE WITHOUT WRITTEN CONSENT.

CUSTOMER NAME: \_\_\_\_\_  
 APPROVED BY: \_\_\_\_\_ DATE: \_\_\_\_\_

**CONTAINMENT SOLUTIONS®**

DRAWN BY: D. ROVANG      DATE DRAWN: 12-21-16  
 DWG NUMBER: 5106934      SCALE: 1:32  
 REV:      REV BY:      DATE:      SHEET: 1 OF 1