

**NOTE:**  
 OVERALL SHIPPING DIMENSION: 22'-3" L X 5'-0" W X 6'-7" H

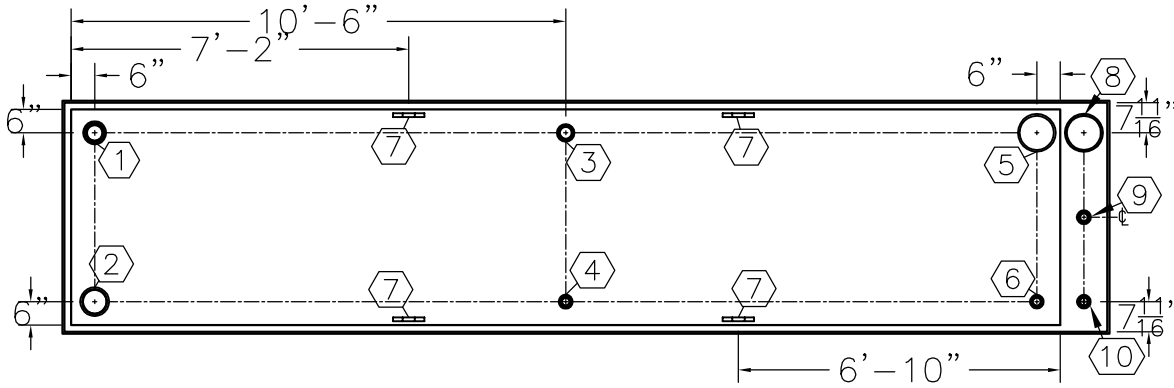

TOP VIEW

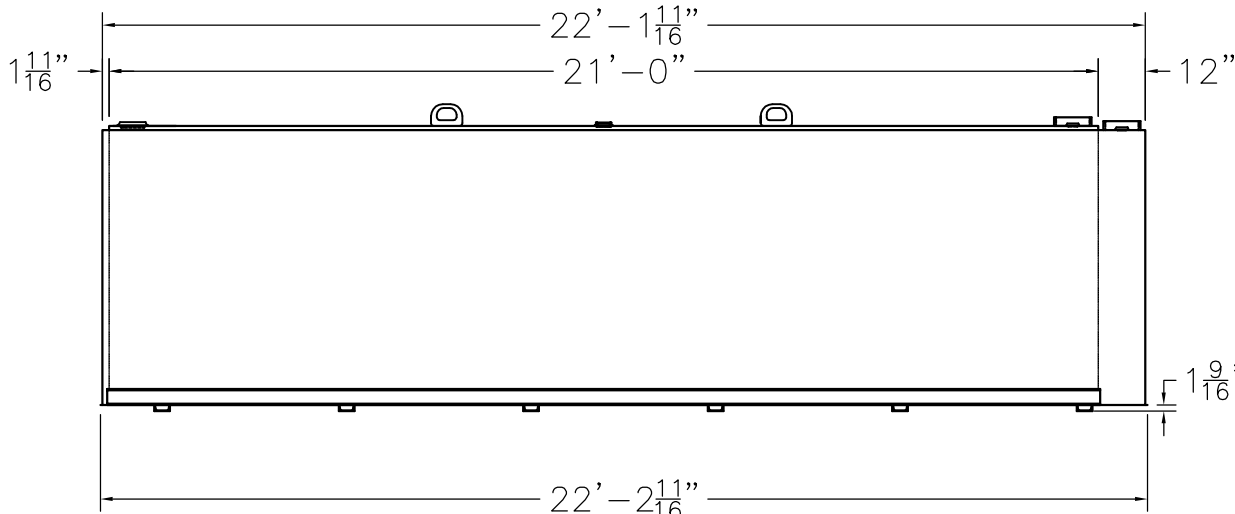

ELEVATION

ITEM	SIZE	SUGGESTED FUNCTION
1	4"	SPARE
2	6"	FILL
3	3"	PRIMARY TANK WORKING VENT
4	2"	MECHANICAL GAUGE/SPARE
5	8"	PRIMARY TANK EMERGENCY VENT
6	2"	SPARE
7	LARGE	LIFTING LUG
8	8"	SECONDARY CONTAINMENT EMERGENCY VENT
9	2"	SECONDARY MONITOR PORT
10	2"	SECONDARY WORKING VENT

**TANK SPECIFICATIONS**

VENTING CAPACITY: PRIMARY TANK - 312,000 CUBIC FEET PER HOUR  
 SECONDARY TANK - 354,000 CUBIC FEET PER HOUR  
 MATERIAL: PRIMARY TANK - 3/16" THICK  
 SECONDARY TANK - 3/16" THICK

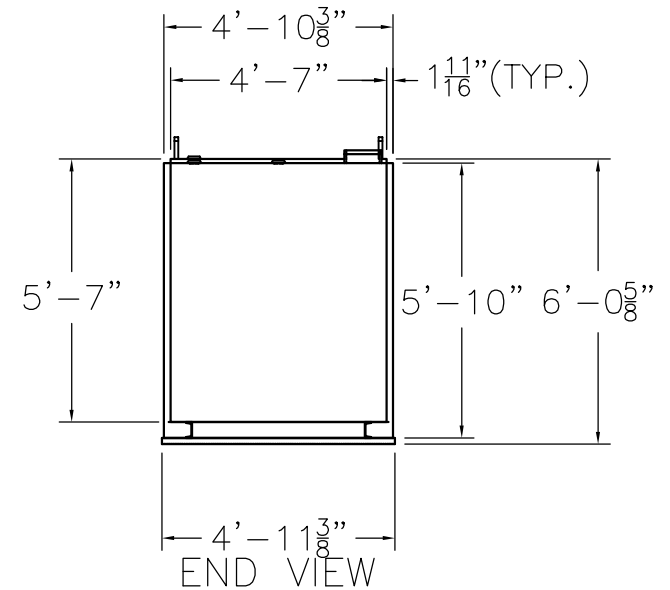

END VIEW

PRODUCT CODE	GALLONS	DESCRIPTION	OVERALL SIZE	SHIP WT.
LCAA104MDS000	4,000	UL-142 DOUBLE WALL LUBE CUBE TANK	22'-3" L X 5'-0" W X 6'-1" L	8,150 LBS.

THIS DRAWING AND DESIGN SHOWN HEREIN IS THE PROPERTY OF CONTAINMENT SOLUTIONS. USE OR COPIES THEREOF CANNOT BE MADE WITHOUT WRITTEN CONSENT.

CUSTOMER NAME: \_\_\_\_\_  
 APPROVED BY: \_\_\_\_\_ DATE: \_\_\_\_\_



DRAWN BY: D. ROVANG	DATE DRAWN: 01-01-14
DWG NUMBER: 5100105	SCALE: 1:50
REV: _____	REV BY: _____
DATE: _____	SHEET: 1 OF 1