

NOTE:
OVERALL SHIPPING DIMENSION: 5'-5" L X 3'-10" W X 5'-2" H

ITEM	SIZE	SUGGESTED FUNCTION
1	2"	SPARE
2	2"	FILL
3	1/2"	DRAIN FOR SPILLBOX
4	7 GAL.	SPILLBOX, DWG."SBB002"
5	2"	PRIMARY TANK WORKING VENT
6	2"	MECHANICAL GAUGE/SPARE
7	4"	PRIMARY TANK EMERGENCY VENT
8	2"	RETURN
9	2"	SUPPLY
10	SMALL	LIFTING LUG
11	4"	SECONDARY CONTAINMENT EMERGENCY VENT
12	2"	SECONDARY MONITOR PORT
13	2"	SECONDARY WORKING VENT

TANK SPECIFICATIONS

VENTING CAPACITY: PRIMARY TANK - 84,200 CUBIC FEET PER HOUR
 SECONDARY TANK - 94,800 CUBIC FEET PER HOUR

MATERIAL: PRIMARY TANK - 10 GA.
 SECONDARY TANK - 10 GA.

TOP VIEW

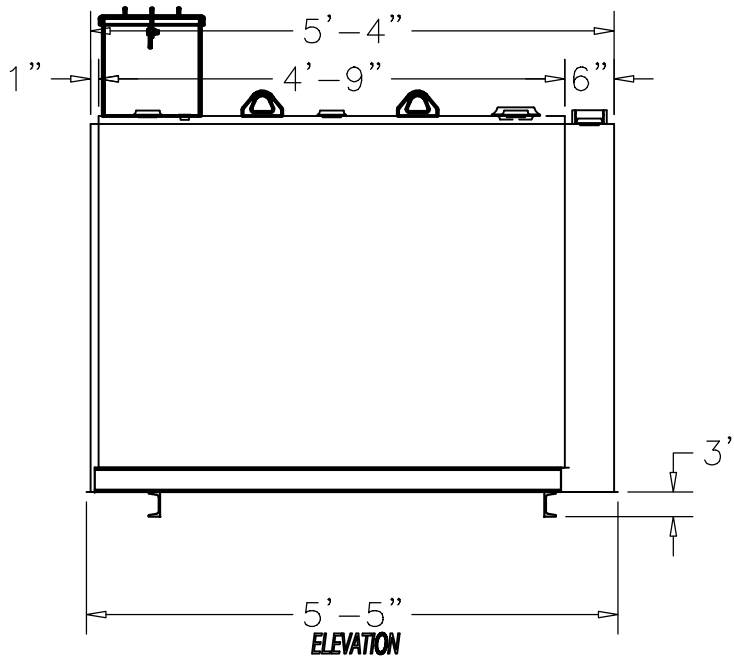

ELEVATION

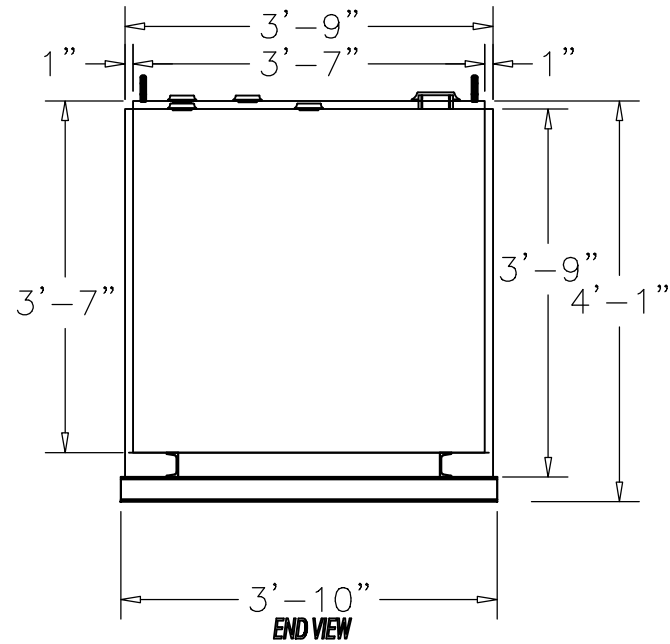

END VIEW

PRODUCT CODE	GALLONS	DESCRIPTION	OVERALL SIZE	SHIP WT.
GCAA1450DS001	450	UL-142 DOUBLE WALL GEN CUBE TANK W/SPILLBOX	5'-5" L X 3'-10" W X 4'-1" H	1,150 LBS.

CONTAINMENT SOLUTIONS®

THIS DRAWING AND DESIGN SHOWN HEREIN IS THE PROPERTY OF CONTAINMENT SOLUTIONS. USE OR COPIES THEREOF CANNOT BE MADE WITHOUT WRITTEN CONSENT.

CUSTOMER NAME: _____
APPROVED BY: _____ DATE: _____

DRAWN BY: D. ROVANG DATE DRAWN: 01-01-17
 DWG NUMBER: 5107544 SCALE: 1:24
 REV: _____ REV BY: _____ DATE: _____ SHEET: 1 OF 1