

NOTE:

OVERALL SHIPPING DIMENSION: 4'-10" L X 3'-10" W X 6'-2" H

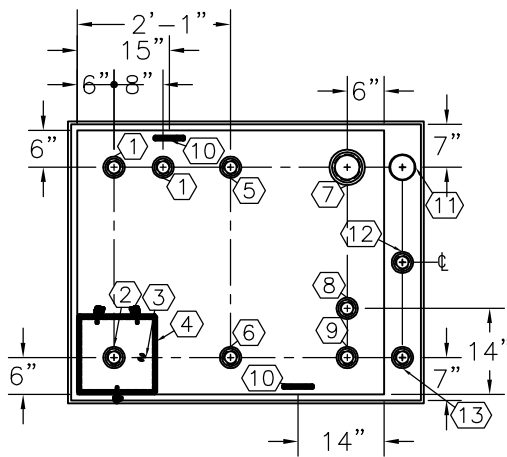

TOP VIEW

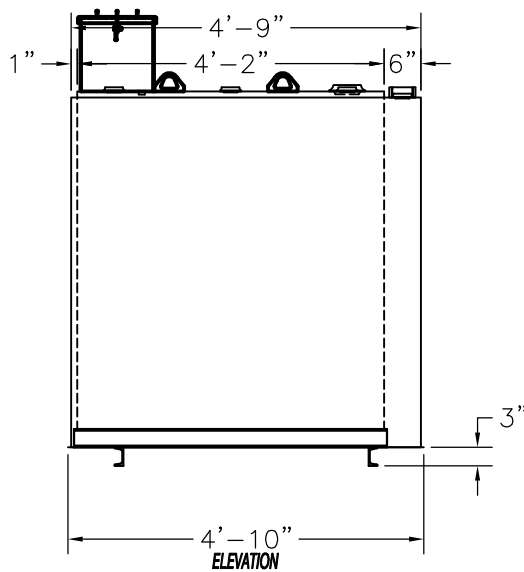

ELEVATION

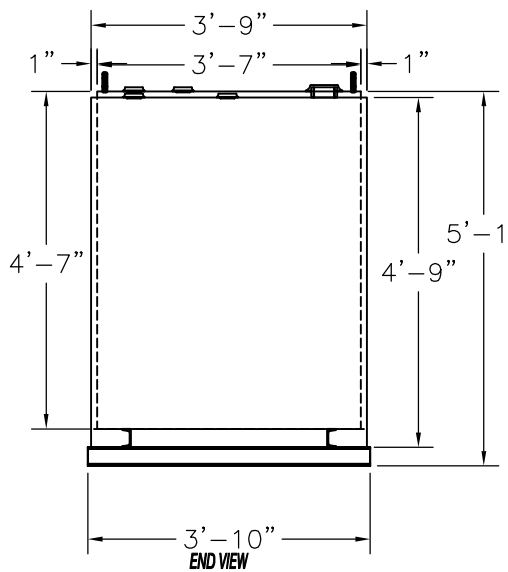

END VIEW

ITEM	SIZE	SUGGESTED FUNCTION
1	2"	SPARE
2	2"	FILL
3	1/2"	DRAIN FOR SPILLBOX
4	7 GAL.	SPILLBOX, DWG."SBB002"
5	2"	PRIMARY TANK WORKING VENT
6	2"	MECHANICAL GAUGE/ SPARE
7	4"	PRIMARY TANK EMERGENCY VENT
8	2"	RETURN
9	2"	SUPPLY
10	SMALL	LIFTING LUG
11	4"	SECONDARY CONTAINMENT EMERGENCY VENT
12	2"	SECONDARY MONITOR PORT/ SPARE
13	2"	SECONDARY WORKING VENT

TANK SPECIFICATIONS

VENTING CAPACITY: PRIMARY TANK - 94,800 CUBIC FEET PER HOUR

SECONDARY TANK - 104,600 CUBIC FEET PER HOUR

MATERIAL: PRIMARY TANK - 10 GA.

SECONDARY TANK - 10 GA.

PRODUCT CODE	GALLONS	DESCRIPTION	OVERALL SIZE	SHIP WT.
GCAA1500D8502	500	UL-142 DOUBLE WALL LUBE CUBE TANK	4'-10" L X 3'-10" W X 5'-1" H	1,350 LBS.

THIS DRAWING AND DESIGN SHOWN HEREIN IS THE PROPERTY OF CONTAINMENT SOLUTIONS. USE OR COPIES THEREOF CANNOT BE MADE WITHOUT WRITTEN CONSENT.

CUSTOMER NAME: _____

APPROVED BY: _____ DATE: _____

CONTAINMENT SOLUTIONS®

DRAWN BY: D. ROVANG	DATE DRAWN: 01-23-17
DWG NUMBER: 5106977	SCALE: 1:24
REV: _____	REV BY: _____
DATE: _____	SHEET: 1 OF 1