

**NOTE:**  
**OVERALL SHIPPING DIMENSION: 5'-2" L X 3'-10" W X 6'-2" H**

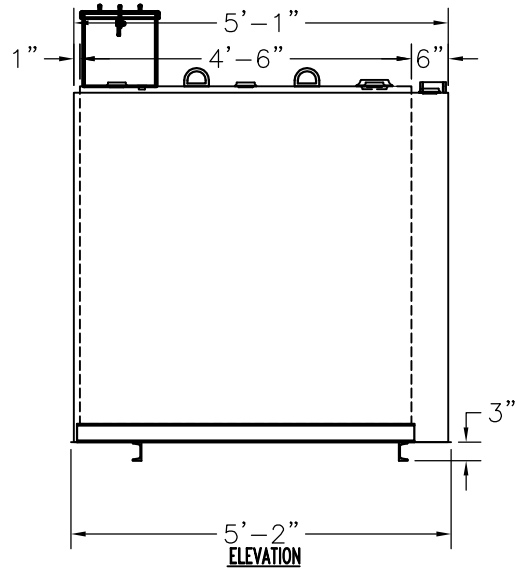
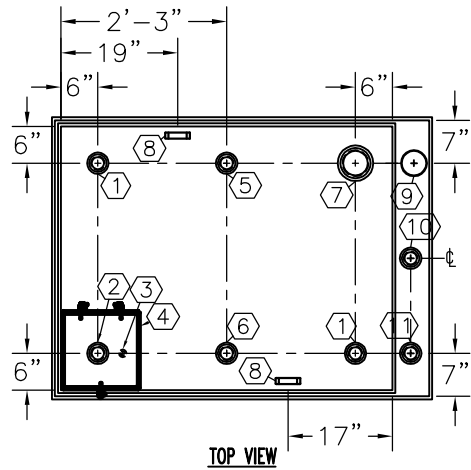

ITEM	SIZE	SUGGESTED FUNCTION
1	2"	SPARE
2	2"	FILL
3	1/2"	DRAIN FOR SPILLBOX
4	7 GAL.	SPILLBOX, DWG."SBB002"
5	2"	PRIMARY TANK WORKING VENT
6	2"	MECHANICAL GAUGE/SPARE
7	4"	PRIMARY TANK EMERGENCY VENT
8	SMALL	LIFTING LUG
9	4"	SECONDARY CONTAINMENT EMERGENCY VENT
10	2"	SECONDARY MONITOR PORT
11	2"	SECONDARY WORKING VENT

**TANK SPECIFICATIONS**

VENTING CAPACITY: PRIMARY TANK - 94,800 CUBIC FEET PER HOUR  
 SECONDARY TANK - 126,000 CUBIC FEET PER HOUR  
 MATERIAL: PRIMARY TANK - 10 GA.  
 SECONDARY TANK - 10 GA.

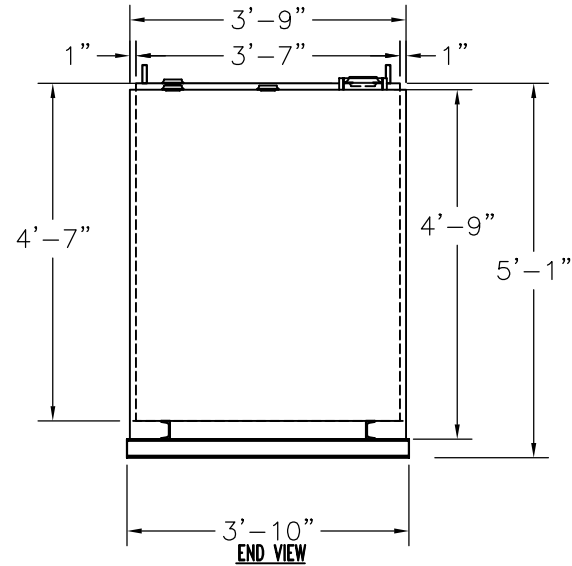

PRODUCT CODE	GALLONS	DESCRIPTION	OVERALL SIZE	SHIP WT.
LCAA1550D8514	550	UL-142 DOUBLE WALL LUBE CUBE TANK	5'-2" L X 3'-10" W X 5'-1" H	1,400 LBS.

THIS DRAWING AND DESIGN SHOWN HEREIN IS THE PROPERTY OF CONTAINMENT SOLUTIONS. USE OR COPIES THEREOF CANNOT BE MADE WITHOUT WRITTEN CONSENT.

CUSTOMER NAME: \_\_\_\_\_  
**APPROVED** BY: \_\_\_\_\_ DATE: \_\_\_\_\_

**CONTAINMENT SOLUTIONS**

DRAWN BY: R. OXNER | DATE DRAWN: 04-01-16  
 DWG NUMBER: 5106590 | SCALE: 1:32  
 REV: A | REV BY: DAR | DATE: 10-20-17 | SHEET: 1 OF 1