

NOTE:
OVERALL SHIPPING DIMENSION: 20'-3" L X 8'-0" W X 7'-2" H

ITEM	SIZE	SUGGESTED FUNCTION
1	4"	SPARE
2	6"	FILL
3	1/2"	DRAIN FOR SPILLBOX
4	7 GAL.	SPILLBOX, DWG."SBB002"
5	3"	PRIMARY TANK WORKING VENT
6	18"	ABOVE LIQUID MANHOLE, DWG."MHBO05"
7	2"	MECHANICAL GAUGE/SPARE
8	8"	PRIMARY TANK EMERGENCY VENT
9	2"	SPARE
10	LARGE	LIFTING LUG
11	8"	SECONDARY CONTAINMENT EMERGENCY VENT
12	2"	SECONDARY MONITOR PORT
13	2"	SECONDARY WORKING VENT

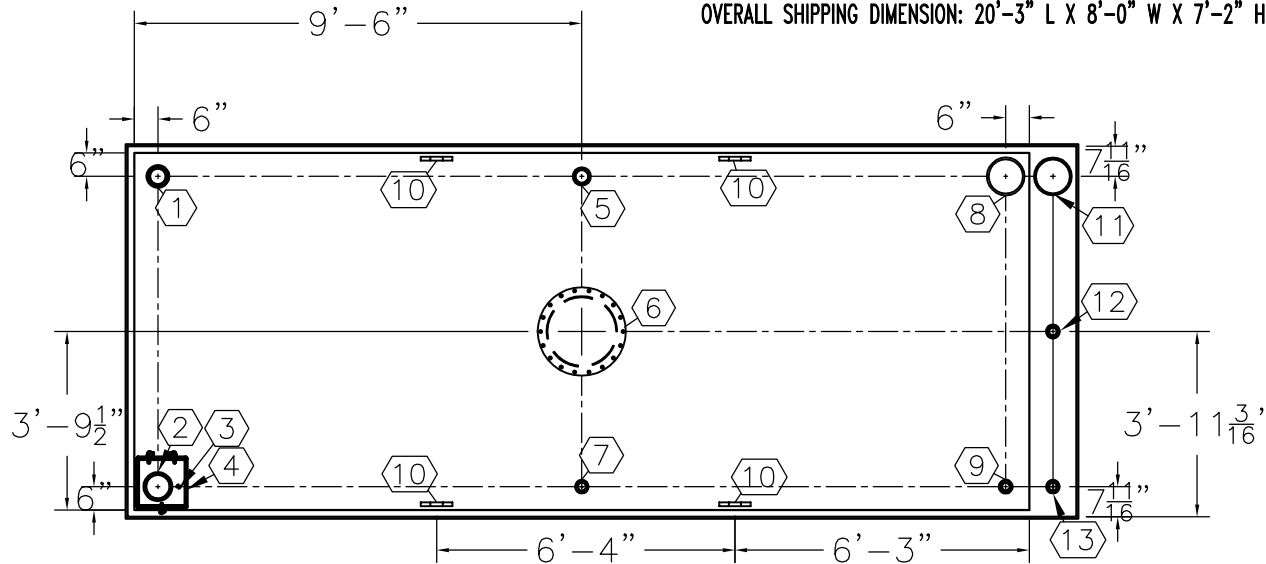

TOP VIEW

TANK SPECIFICATIONS

VENTING CAPACITY: PRIMARY TANK - 354,000 CUBIC FEET PER HOUR
 SECONDARY TANK - 354,000 CUBIC FEET PER HOUR
 MATERIAL: PRIMARY TANK - 1/4" THICK
 SECONDARY TANK - 3/16" THICK

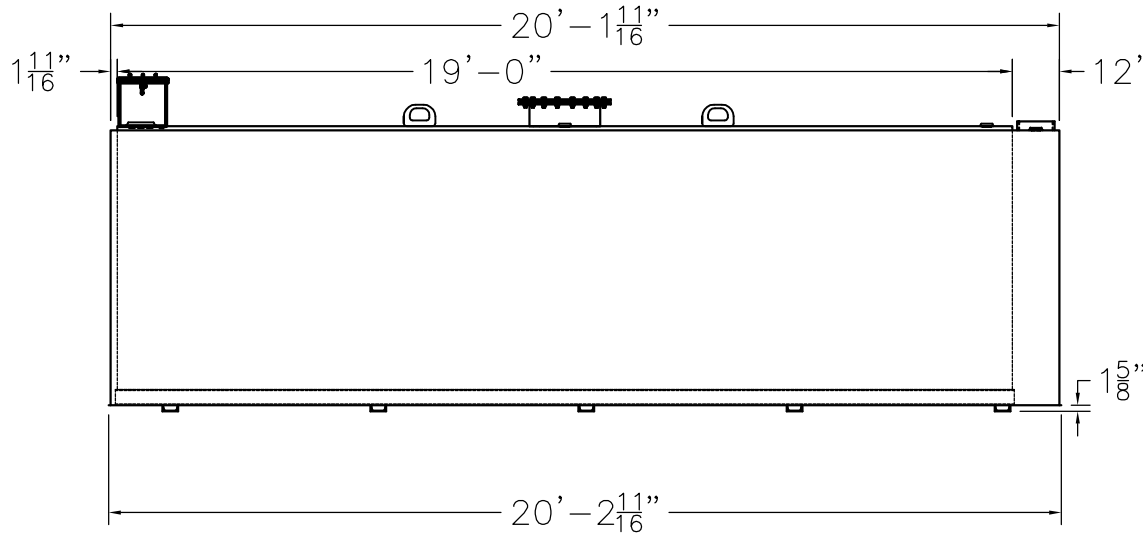

ELEVATION

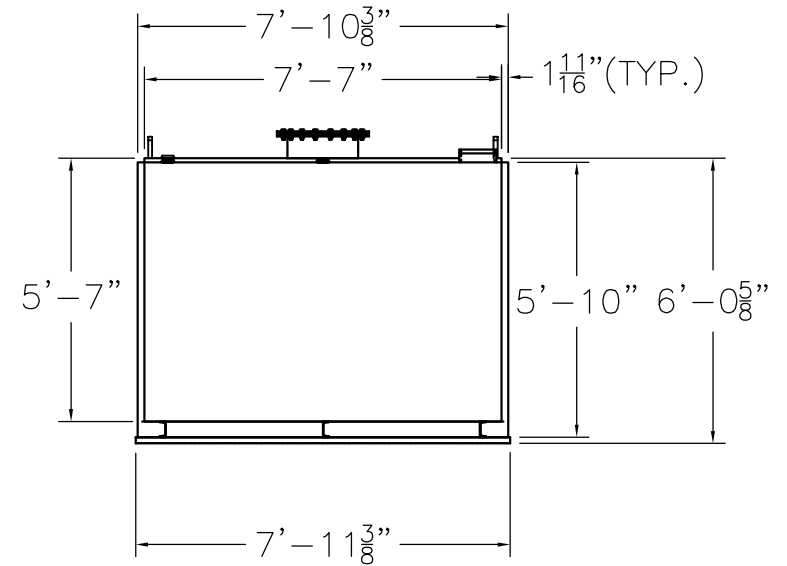

END VIEW

PRODUCT CODE	GALLONS	DESCRIPTION	OVERALL SIZE	SHIP WT.
LCAA106MDS001	6,000	UL-142 DOUBLE WALL LUBE CUBE TANK W/SPILLBOX	20'-3" L X 8'-0" W X 6'-1" H	11,400 LBS.

CONTAINMENT SOLUTIONS

THIS DRAWING AND DESIGN SHOWN HEREIN IS THE PROPERTY OF CONTAINMENT SOLUTIONS. USE OR COPIES THEREOF CANNOT BE MADE WITHOUT WRITTEN CONSENT.

CUSTOMER NAME: _____
 APPROVED BY: _____ DATE: _____

DRAWN BY: D. ROVANG DATE DRAWN: 01-01-14
 DWG NUMBER: 5100126 SCALE: 1:50
 REV: _____ REV BY: _____ DATE: _____ SHEET: 1 OF 1