

NOTE:
 OVERALL SHIPPING DIMENSION: 1'-11" L X 2'-10" W X 4'-2" H

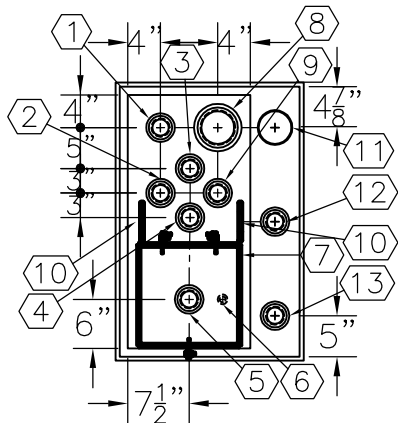

TOP VIEW

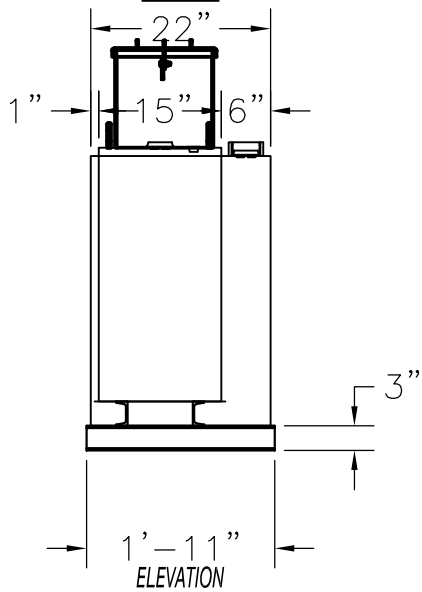

ELEVATION

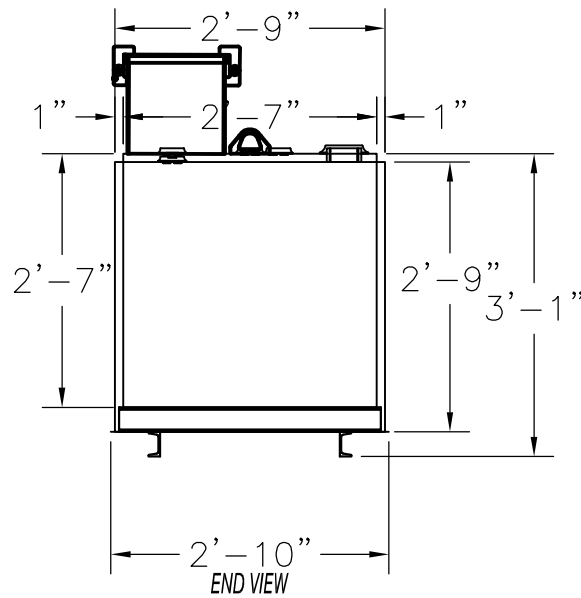

END VIEW

ITEM	SIZE	SUGGESTED FUNCTION
1	2"	PRIMARY TANK WORKING VENT
2	2"	MECHANICAL GAUGE/SPARE
3	2"	RETURN
4	2"	SUPPLY
5	2"	FILL
6	1/2"	DRAIN FOR SPILLBOX
7	7 GAL.	SPILLBOX, DWG."SBB002"
8	4"	PRIMARY TANK EMERGENCY VENT
9	2"	SPARE
10	SMALL	LIFTING LUG
11	4"	SECONDARY CONTAINMENT EMERGENCY VENT
12	2"	SECONDARY MONITOR PORT
13	2"	SECONDARY WORKING VENT

TANK SPECIFICATIONS

VENTING CAPACITY: PRIMARY TANK - 31,600 CUBIC FEET PER HOUR

SECONDARY TANK - 31,600 CUBIC FEET PER HOUR

MATERIAL: PRIMARY TANK - 10 GA.

SECONDARY TANK - 10 GA.

PRODUCT CODE	GALLONS	DESCRIPTION	OVERALL SIZE	SHIP WT.
GCAA1060DS001	60	UL-142 DOUBLE WALL GEN CUBE TANK W/SPILLBOX	1'-11" L X 2'-10" W X 3'-1" H	385 LBS.

THIS DRAWING AND DESIGN SHOWN HEREIN IS THE PROPERTY OF CONTAINMENT SOLUTIONS. USE OR COPIES THEREOF CANNOT BE MADE WITHOUT WRITTEN CONSENT.

CUSTOMER NAME: _____

APPROVED BY: _____ DATE: _____

CONTAINMENT SOLUTIONS

DRAWN BY: D. ROVANG DATE DRAWN: 01-01-14
 DWG NUMBER: 5104001 SCALE: 1:24
 REV: REV BY: DATE: SHEET: 1 OF 1