

NOTE:
 OVERALL SHIPPING DIMENSION: 5'-7" L X 3'-10" W X 5'-4" H

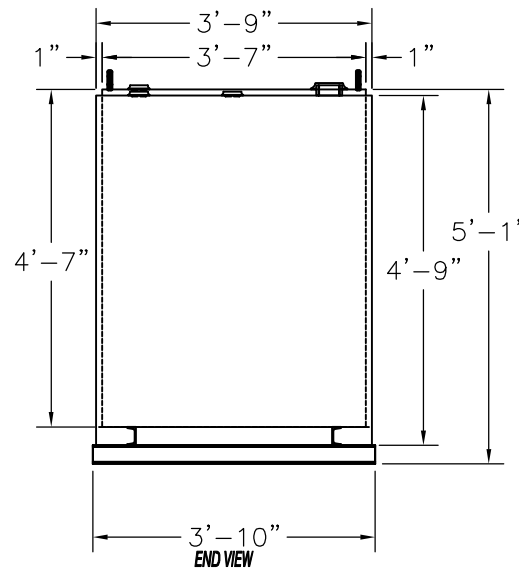
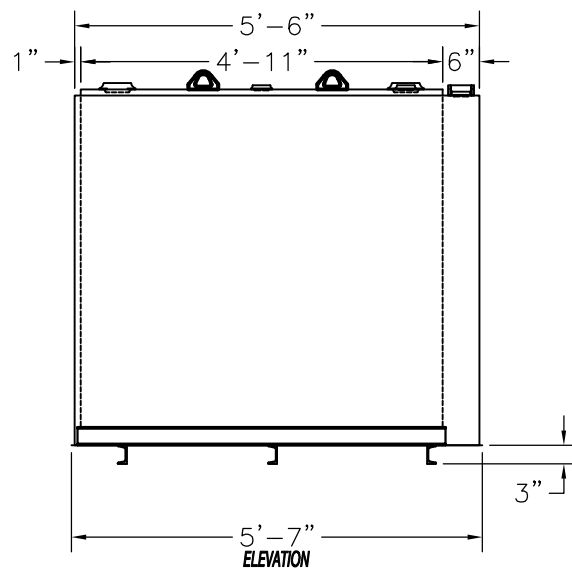
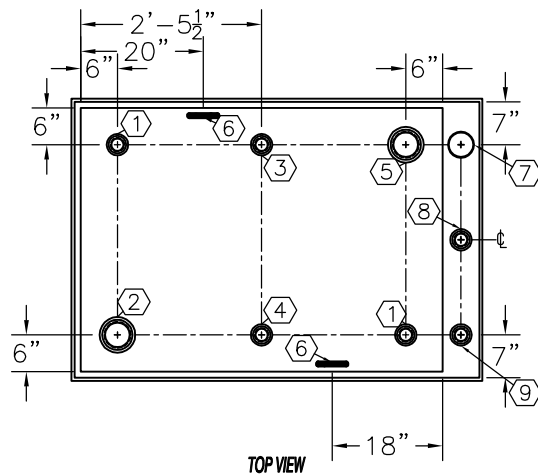

ITEM	SIZE	SUGGESTED FUNCTION
1	2"	SPARE
2	4"	FILL
3	2"	PRIMARY TANK WORKING VENT
4	2"	MECHANICAL GAUGE/ SPARE
5	4"	PRIMARY TANK EMERGENCY VENT
6	SMALL	LIFTING LUG
7	4"	SECONDARY CONTAINMENT EMERGENCY VENT
8	2"	SECONDARY MONITOR PORT/ SPARE
9	2"	SECONDARY WORKING VENT

TANK SPECIFICATIONS

VENTING CAPACITY: PRIMARY TANK - 105,000 CUBIC FEET PER HOUR

SECONDARY TANK - 126,000 CUBIC FEET PER HOUR

MATERIAL: PRIMARY TANK - 10 GA.

SECONDARY TANK - 10 GA.

PRODUCT CODE	GALLONS	DESCRIPTION	OVERALL SIZE	SHIP WT.
LCAA1600D8516	600	UL-142 DOUBLE WALL LUBE CUBE TANK	5'-7" L X 3'-10" W X 5'-1" H	1,500 LBS.

THIS DRAWING AND DESIGN SHOWN HEREIN IS THE PROPERTY OF CONTAINMENT SOLUTIONS. USE OR COPIES THEREOF CANNOT BE MADE WITHOUT WRITTEN CONSENT.

CUSTOMER NAME: _____

APPROVED BY: _____ DATE: _____

CONTAINMENT SOLUTIONS®

DRAWN BY: D. ROVANG DATE DRAWN: 05-25-16
 DWG NUMBER: 5106671 SCALE: 1:24
 REV: _____ REV BY: _____ DATE: _____ SHEET: 1 OF 1