

7/8 Fiberglass Baffle (With Flow-Through Hole(s))

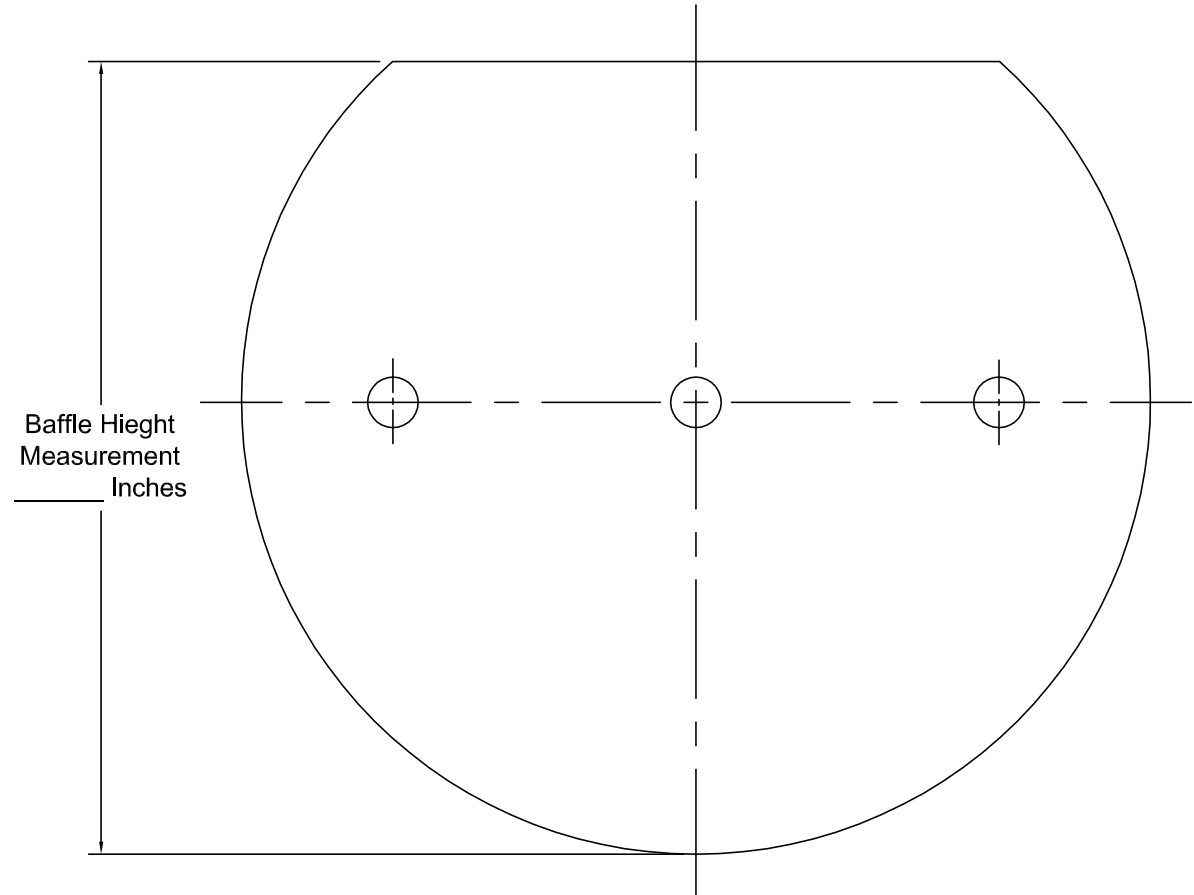
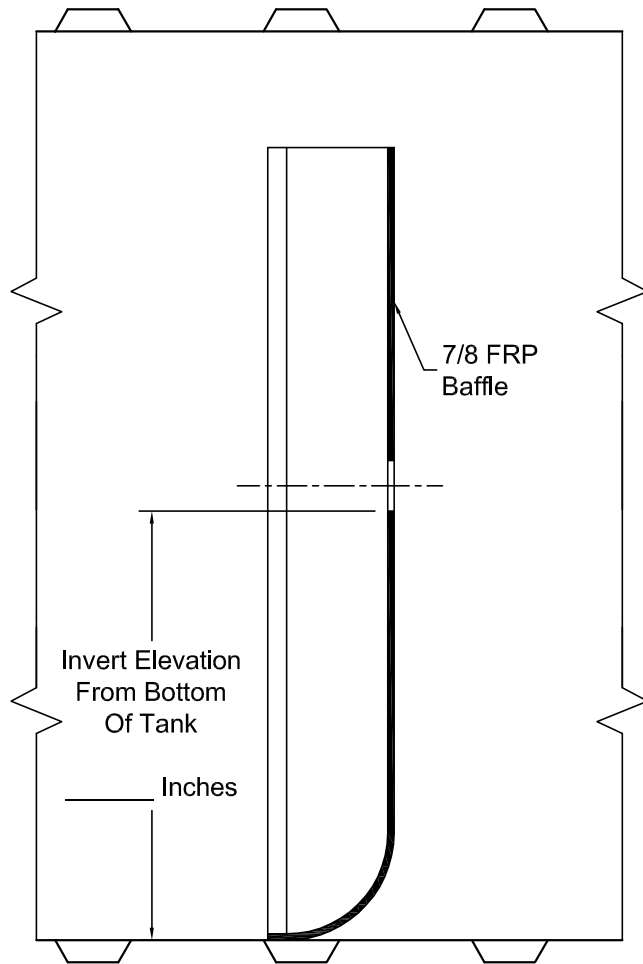

Baffle Crossover Will Be: _____ Flow-Through Hole(s)
 _____ Crossover Piping

If Using Flow-Through Holes: _____ Diameter Of Hole(s)
 _____ Quantity Of Hole(s)

If Using Crossover Piping Complete Dimension Requirements



CONTAINMENT
SOLUTIONSSM