

TOP VIEW

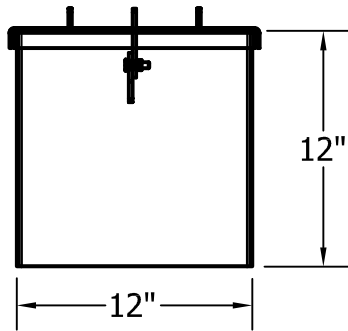

ELEVATION VIEW

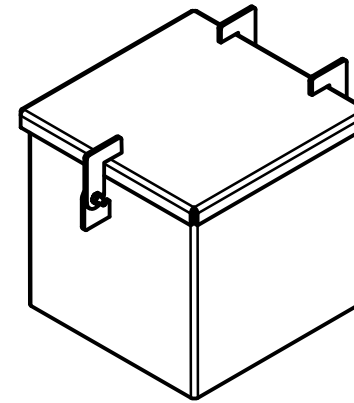

ISOMETRIC

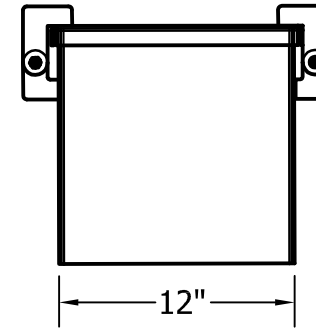

END VIEW

NOTES:

1. SPILLBOX BODY SHALL BE 10 GA. CARBON STEEL.
2. SPILLBOX LID SHALL BE STEEL.
3. ALL FASTENERS SHALL BE STAINLESS STEEL.
4. SPILLBOX SHALL BE WELDED TO TANK.
5. SPILLBOX LID SHALL OPEN NO LESS THAN 135° PAST HORIZONTAL.
6. EXTERIOR COATING SHALL BE THE SAME AS TANK, UNLESS NOTED.

PRODUCT CODE	GALLONS	DESCRIPTION	OVERALL SIZE	SHIP WT.
SBB002	7	SPILLBOX	12" L X 12" W X 12" H	27 LBS.

CONTAINMENT SOLUTIONS

THIS DRAWING AND DESIGN SHOWN HEREIN IS THE PROPERTY OF CONTAINMENT SOLUTIONS. USE OR COPIES THEREOF CANNOT BE MADE WITHOUT WRITTEN CONSENT.

CUSTOMER NAME: _____
APPROVED BY: _____ DATE: _____

DRAWN BY: D. ROVANG	DATE DRAWN: 01-01-14
DWG NUMBER: SBB002	SCALE: 1:10
REV: _____	REV BY: _____
DATE: _____	SHEET: 1 OF 1