

# FLOWTITE PRODUCTS

## GREASE INTERCEPTOR

NOTE: CUSTOMER SUPPLIED  
"ASTM C-1644" APPROVED  
FLEXIBLE PIPING COUPLING  
REQUIRED ON TANGENTIALLY  
MTD. NOZZLES, & PIPES

SHELL CODES: 1-E8S06SD, 1-E8SECSD



THIS IS AN IAPMO APPROVED TANK  
THE ONLY CHANGE ALLOWED TO  
THIS TANK IS TO INCREASE THE  
INLET AND OUTLET PIPE DIAMETER.  
MFG. PER. PE-C22.85

### CAPACITIES:

LIQUID OPERATING CAPACITY = 3304 GALS  
FREE SURFACE AREA OF LIQUID = 74 SQ/FT  
GREASE/FOG STORAGE = 1281 GALS 9736 LBS

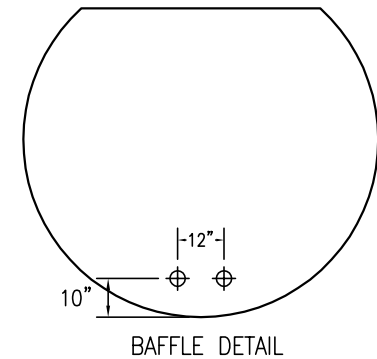
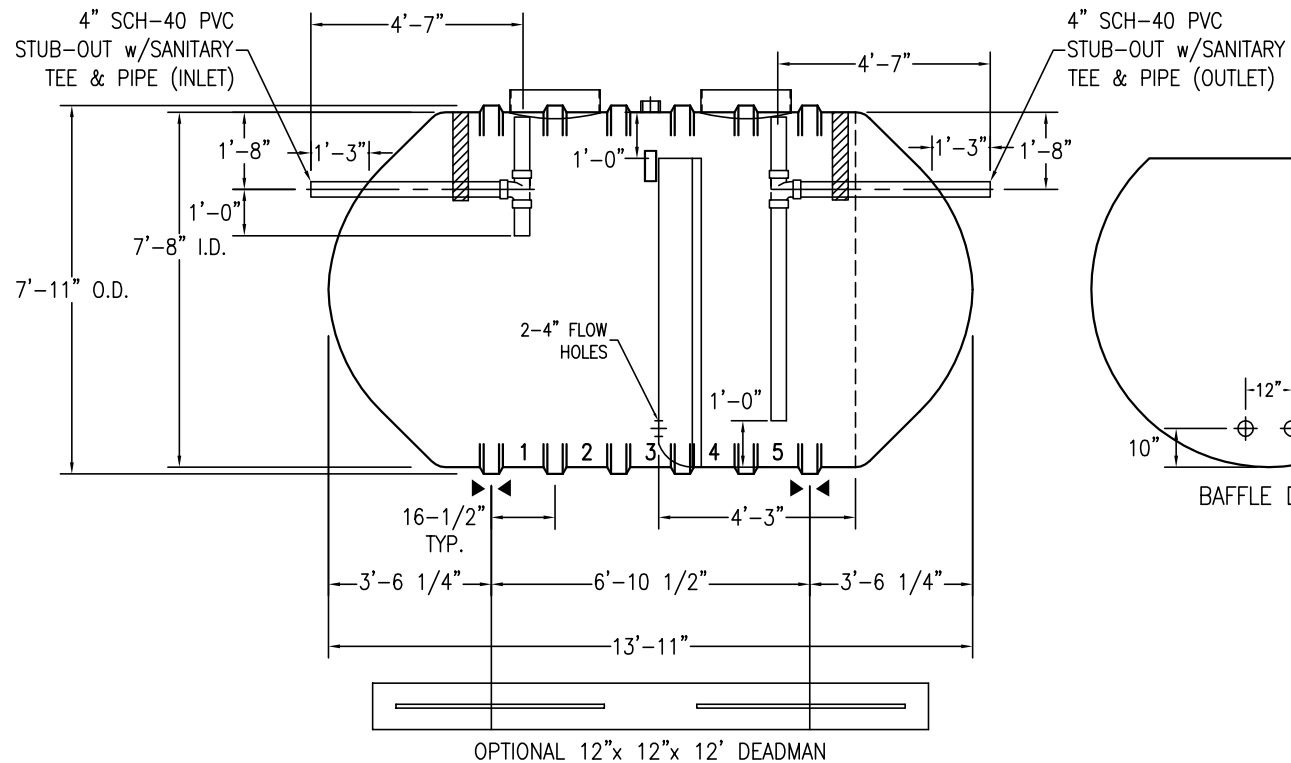
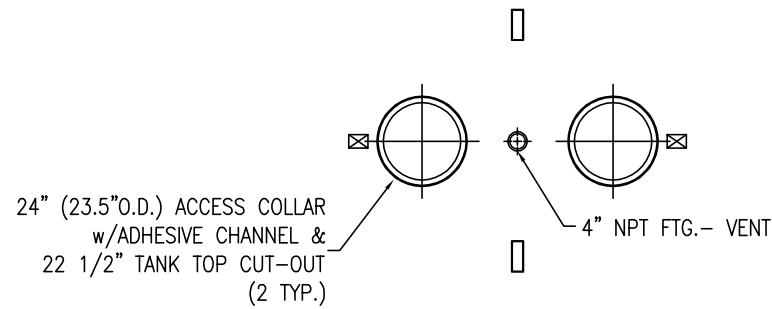

### NOTES:

- ☒ HOLD DOWN STRAP CLIP
- ▶◀ HOLD DOWN STRAP LOCATION
- TYPE "13" LIFT LUG - SD
- TYPE "13" LIFT LUG - HD

SWT G-6 (8')-3300 2B-IG		DATE:	1/1/2014
IAPMO GREASE INTERCEPTOR		DRAWN BY:	R.MOEN
	CAPACITY:	3,998	
	WEIGHT: DRY/WET	1750	
		REVISED:	
		DWG NUMBER:	833CSW-IG