

**NOTE:**  
**OVERALL SHIPPING DIMENSION: 2'-6" L X 2'-10" W X 3'-4" H**

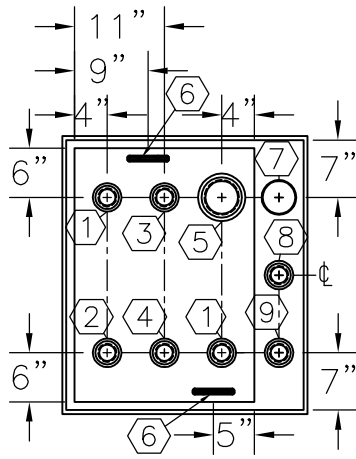

**TOP VIEW**

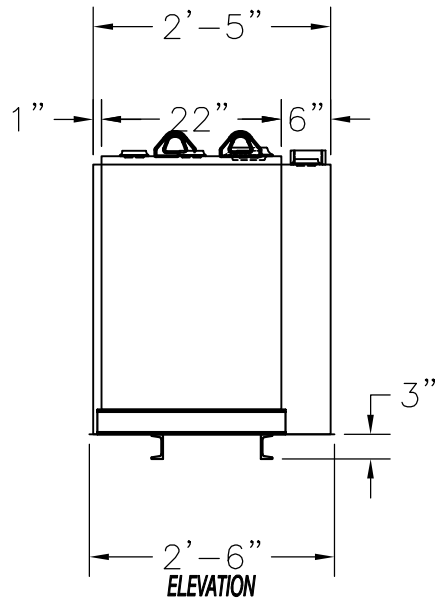

**ELEVATION**

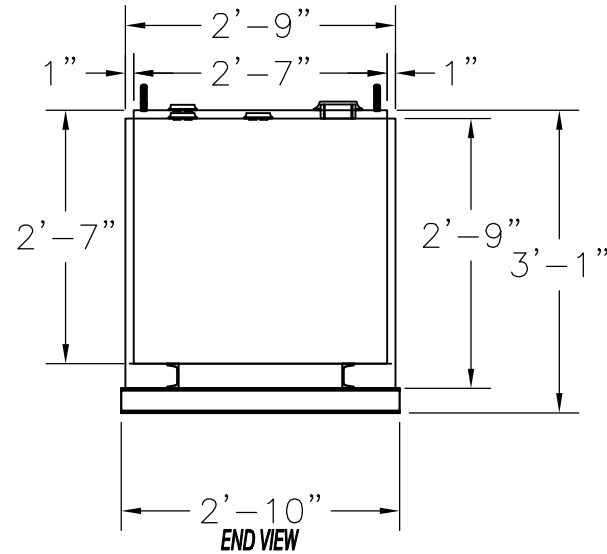

**END VIEW**

ITEM	SIZE	SUGGESTED FUNCTION
1	2"	SPARE
2	2"	FILL
3	2"	PRIMARY TANK WORKING VENT
4	2"	MECHANICAL GAUGE/SPARE
5	4"	PRIMARY TANK EMERGENCY VENT
6	SMALL	LIFTING LUG
7	4"	SECONDARY CONTAINMENT EMERGENCY VENT
8	2"	SECONDARY MONITOR PORT
9	2"	SECONDARY WORKING VENT

**TANK SPECIFICATIONS**

VENTING CAPACITY: PRIMARY TANK - 31,600 CUBIC FEET PER HOUR

SECONDARY TANK - 42,100 CUBIC FEET PER HOUR

MATERIAL: PRIMARY TANK - 10 GA.

SECONDARY TANK - 10 GA.

PRODUCT CODE	GALLONS	DESCRIPTION	OVERALL SIZE	SHIP WT.
LCAA1090DS000	90	UL-142 DOUBLE WALL LUBE CUBE TANK	2'-6" L X 2'-10" W X 3'-1" H	460 LBS.

**CONTAINMENT SOLUTIONS®**

THIS DRAWING AND DESIGN SHOWN HEREIN IS THE PROPERTY OF CONTAINMENT SOLUTIONS. USE OR COPIES THEREOF CANNOT BE MADE WITHOUT WRITTEN CONSENT.

CUSTOMER NAME: \_\_\_\_\_

**APPROVED** BY: \_\_\_\_\_ DATE: \_\_\_\_\_

DRAWN BY: J.HARMON	DATE DRAWN: 12-14-15
DWG NUMBER: 5106475	SCALE: 1:24
REV: B	REV BY: DAR
DATE: 10-30-17	SHEET: 1 OF 1