

NOTE:
OVERALL SHIPPING DIMENSION: 2'-6" L X 2'-10" W X 4'-2" H

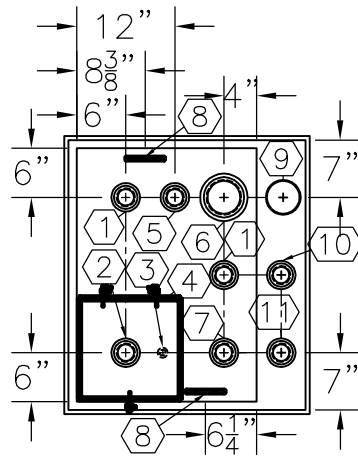

ITEM	SIZE	SUGGESTED FUNCTION
1	2"	SPARE
2	2"	FILL
3	1/2"	DRAIN FOR SPILLBOX
4	7 GAL.	SPILLBOX, DWG."SBB002"
5	2"	PRIMARY TANK WORKING VENT
6	4"	PRIMARY TANK EMERGENCY VENT
7	2"	MECHANICAL GAUGE/SPARE
8	SMALL	LIFTING LUG
9	4"	SECONDARY CONTAINMENT EMERGENCY VENT
10	2"	SECONDARY MONITOR PORT
11	2"	SECONDARY WORKING VENT

TANK SPECIFICATIONS

VENTING CAPACITY: PRIMARY TANK - 31,600 CUBIC FEET PER HOUR
 SECONDARY TANK - 42,100 CUBIC FEET PER HOUR
 MATERIAL: PRIMARY TANK - 10 GA.
 SECONDARY TANK - 10 GA.

TOP VIEW

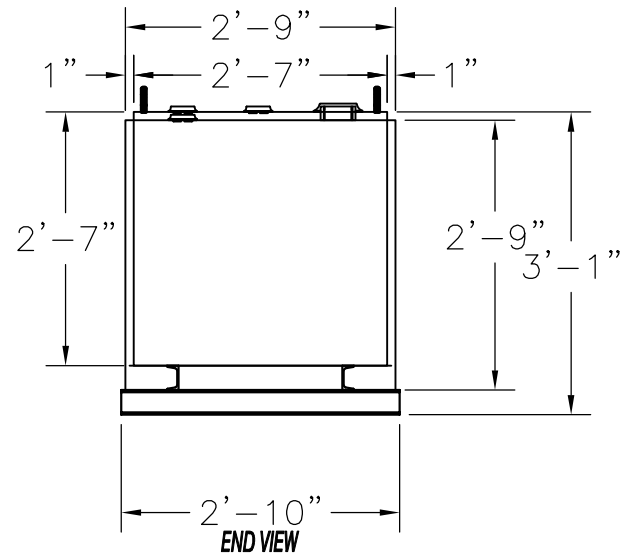
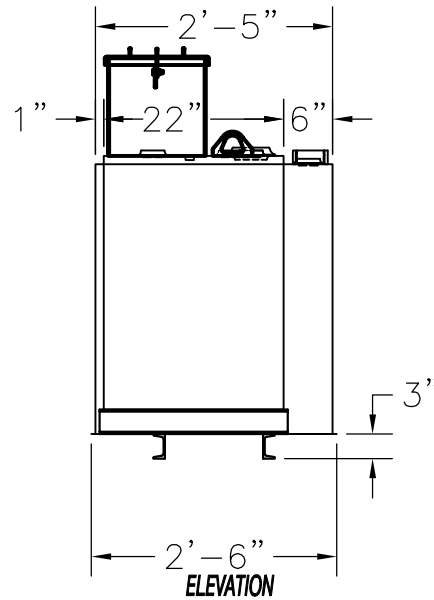

PRODUCT CODE	GALLONS	DESCRIPTION	OVERALL SIZE	SHIP WT.
LCAA1090D8500	90	UL-142 DOUBLE WALL LUBE CUBE TANK W/SPILLBOX	2'-6" L X 2'-10" W X 3'-1" H	485 LBS.

CONTAINMENT SOLUTIONS®

THIS DRAWING AND DESIGN SHOWN HEREIN IS THE PROPERTY OF CONTAINMENT SOLUTIONS. USE OR COPIES THEREOF CANNOT BE MADE WITHOUT WRITTEN CONSENT.

CUSTOMER NAME: _____
APPROVED BY: _____ DATE: _____

DRAWN BY: D. ROVANG | DATE DRAWN: 01-25-12
 DWG NUMBER: 5104797 | SCALE: 1:24
 REV: A | REV BY: DAR | DATE: 10-30-17 | SHEET: 1 OF 1