

NOTE:
OVERALL SHIPPING DIMENSION: 4'-4" L X 2'-5" W X 3'-11" H

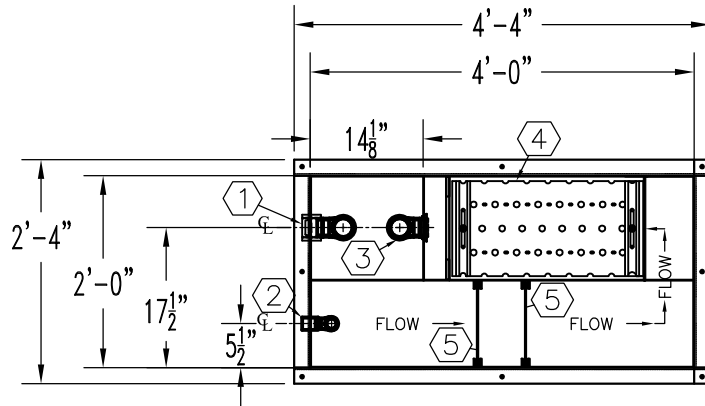

ITEM	SIZE	SUGGESTED FUNCTION
1	2"	EFFLUENT
2	1"	INFLUENT
3	2"	TRANSFER PIPE
4		COALESCER
5		DEBRIS PLATES
6	2" X 9"	OIL EQUALIZING ORIFICE
7		COVER, DWG."CVB001"
8	1"	FLOAT SENSOR NPT FTG.
9	2"	OIL DRAW W/PIPE

TANK SPECIFICATIONS

MATERIAL: PRIMARY TANK - 10 GA.

TOP VIEW
 TOP COVER REMOVED FOR CLARITY
 REFER TO DWG. "CVB001" FOR COVER DETAIL

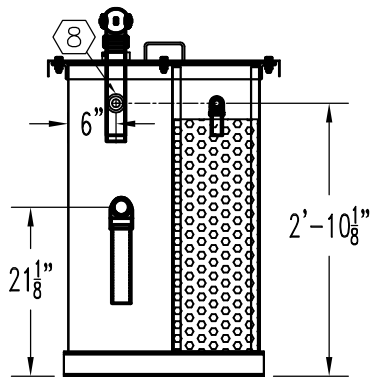

LEFT END VIEW

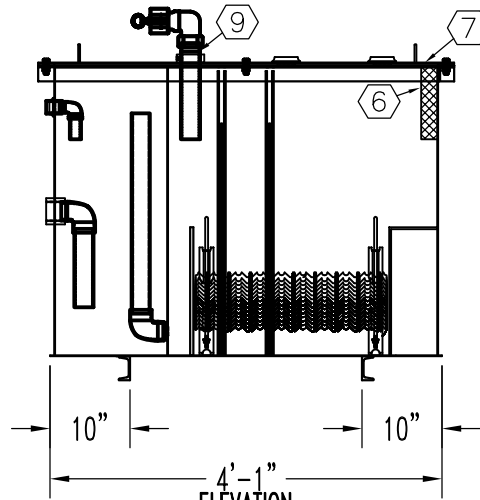

FRONT FACE & BHD REMOVED FOR CLARITY

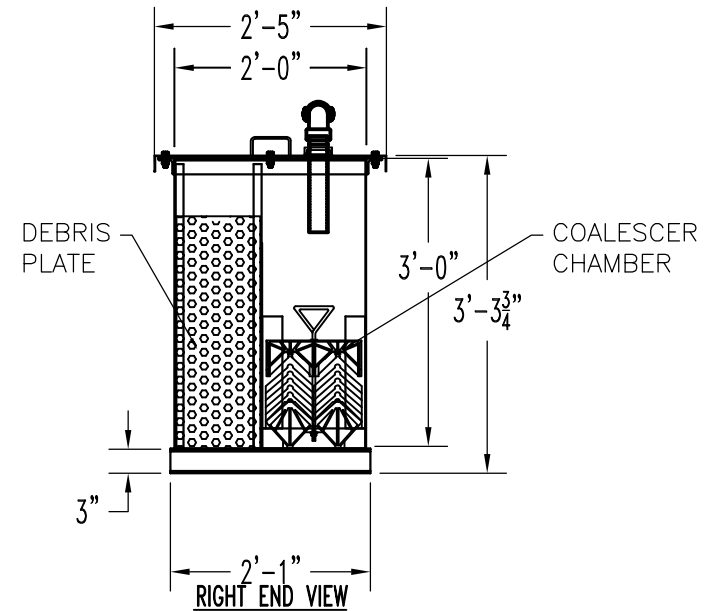

PRODUCT CODE	GALLONS	DESCRIPTION	OVERALL SIZE	SHIP WT.
WSAA1100SS000	100	SINGLE WALL OIL WATER SEPARATOR (10 GPM)	4'-1" L X 2'-1" W X 3'-4" H	625 LBS.

THIS DRAWING AND DESIGN SHOWN HEREIN IS THE PROPERTY OF CONTAINMENT SOLUTIONS. USE OR COPIES THEREOF CANNOT BE MADE WITHOUT WRITTEN CONSENT.

CUSTOMER NAME: _____
APPROVED BY: _____ DATE: _____

CONTAINMENT SOLUTIONS®

DRAWN BY: _____ DATE DRAWN: 01-01-14
 DWG NUMBER: 5100260 SCALE: 1:32
 REV: _____ REV BY: _____ DATE: _____ SHEET: 1 OF 1