

NOTE:

OVERALL SHIPPING DIMENSION: 11'-4" L X 3'-11" W X 4'-11" H

ITEM	SIZE	SUGGESTED FUNCTION
1	6"	EFFLUENT
2	6"	INFLUENT
3	6"	TRANSFER PIPE
4		COALESCER
5		DEBRIS PLATES
6	2" X 18"	OIL EQUALIZING ORIFICE
7		COVER, DWG."CVB005"
8	1"	FLOAT SENSOR NPT FTG.
9	2"	OIL DRAW W/PIPE

TANK SPECIFICATIONS

MATERIAL: PRIMARY TANK - 3/16" THK.

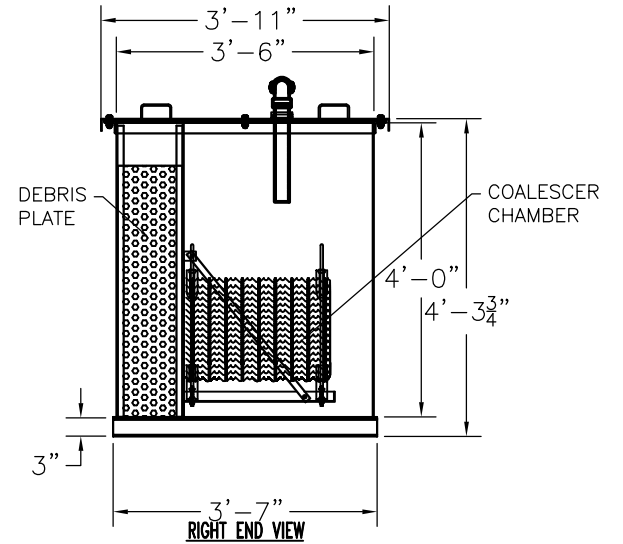
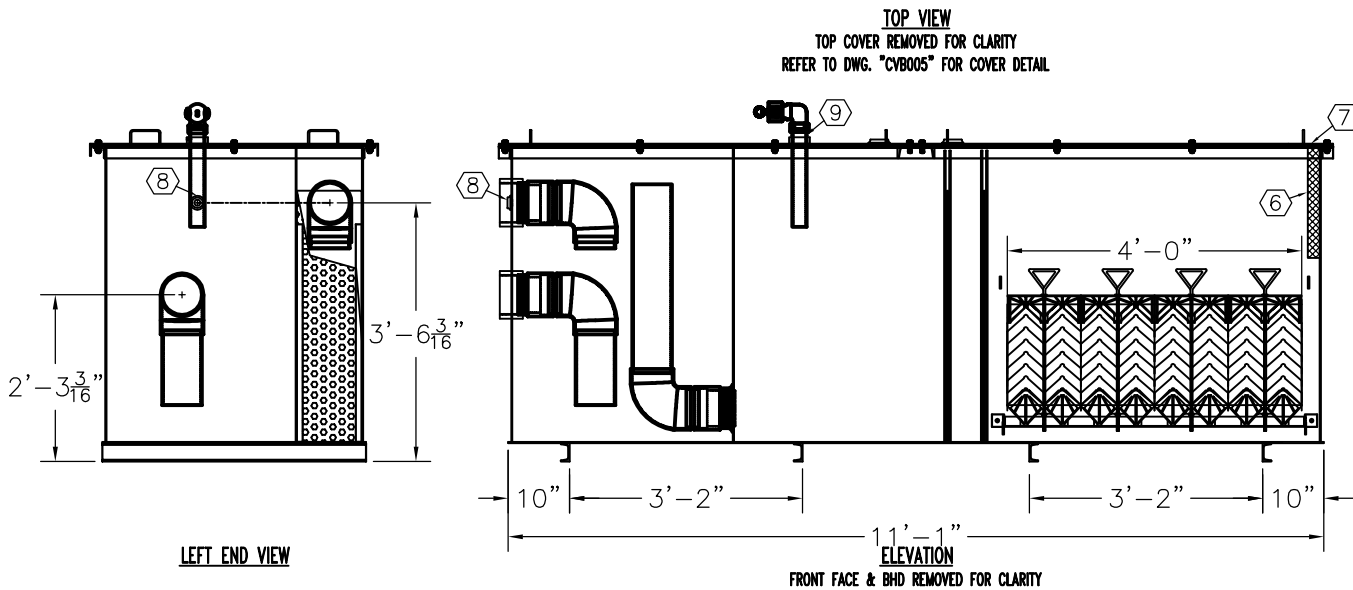
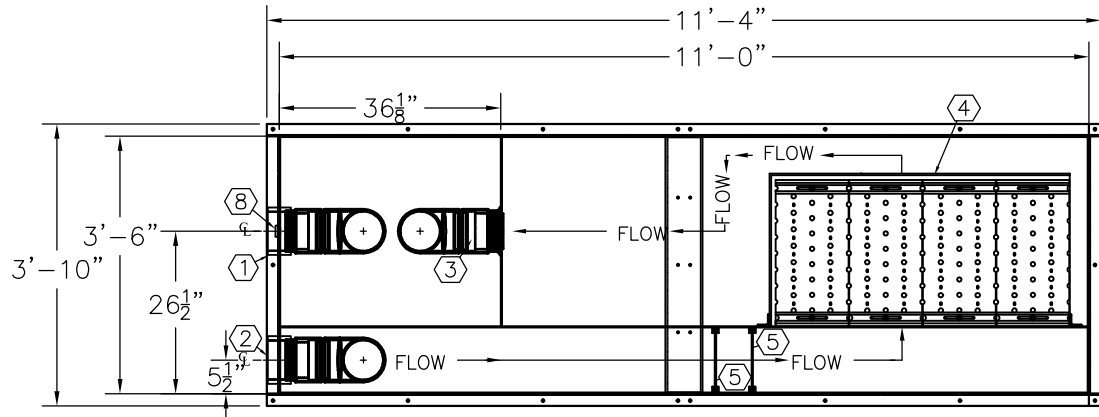

PRODUCT CODE	GALLONS	DESCRIPTION	OVERALL SIZE	SHIP WT.
WSAA101MSS000	1,000	SINGLE WALL OIL WATER SEPARATOR (100 GPM)	11'-1" L X 3'-7" W X 4'-4" H	2,675 LBS.



THIS DRAWING AND DESIGN SHOWN HEREIN IS THE PROPERTY OF CONTAINMENT SOLUTIONS. USE OR COPIES THEREOF CANNOT BE MADE WITHOUT WRITTEN CONSENT.

CUSTOMER NAME: _____
APPROVED BY: _____ DATE: _____

DRAWN BY: _____		DATE DRAWN: 01-01-14	
DWG NUMBER: 5100264		SCALE: 1:32	
REV: _____	REV BY: _____	DATE: _____	SHEET: 1 OF 1