

**NOTE:**

OVERALL SHIPPING DIMENSION: 10'-7" L X 5'-5" W X 4'-11" H

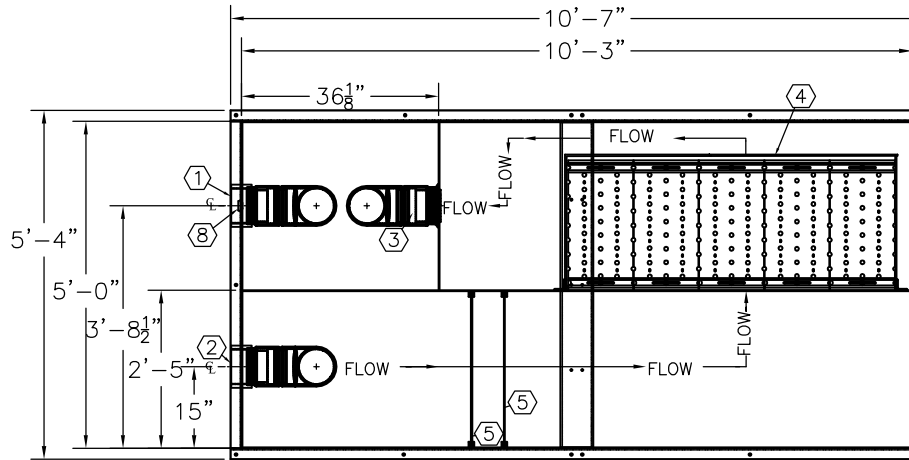

**TOP VIEW**

TOP COVER REMOVED FOR CLARITY  
REFER TO DWG. "CVB023" FOR COVER DETAIL

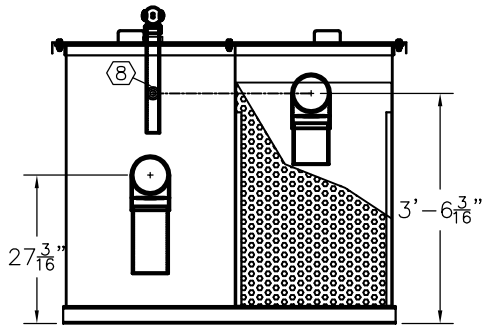

**LEFT END VIEW**

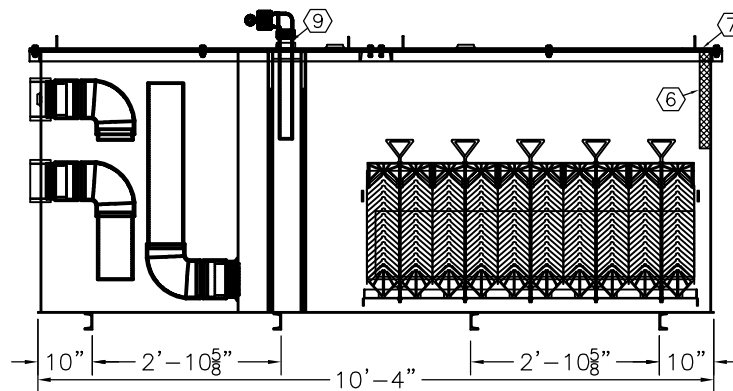

**ELEVATION**

FRONT FACE & BHD REMOVED FOR CLARITY

ITEM	SIZE	SUGGESTED FUNCTION
1	6"	EFFLUENT
2	6"	INFLUENT
3	6"	TRANSFER PIPE
4		COALESCER
5		DEBRIS PLATES
6	2" X 18"	OIL EQUALIZING ORIFICE
7		COVER, DWG."CVB029"
8	1"	FLOAT SENSOR NPT FTG.
9	2"	OIL DRAW W/PIPE

**TANK SPECIFICATIONS**

MATERIAL: PRIMARY TANK - 3/16" THK.

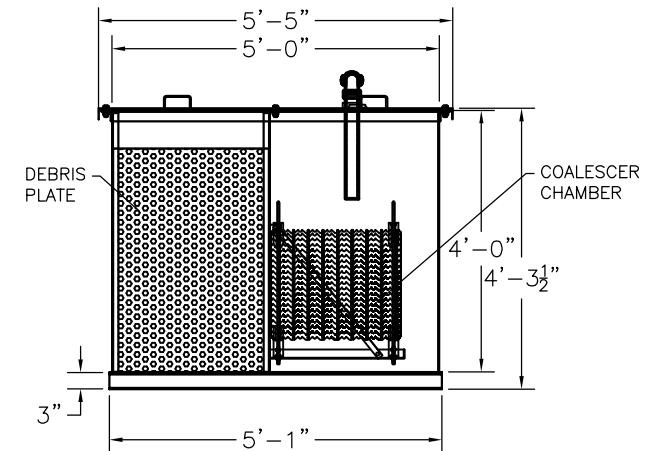

**RIGHT END VIEW**

PRODUCT CODE	GALLONS	DESCRIPTION	OVERALL SIZE	SHIP WT.
WSAA115CSS000	1,500	SINGLE WALL OIL WATER SEPARATOR (150 GPM)	10'-3" L X 5'-1" W X 4'-4" H	3,025 LBS.

THIS DRAWING AND DESIGN SHOWN HEREIN IS THE PROPERTY OF CONTAINMENT SOLUTIONS. USE OR COPIES THEREOF CANNOT BE MADE WITHOUT WRITTEN CONSENT.

CUSTOMER NAME: \_\_\_\_\_

**APPROVED** BY: \_\_\_\_\_ DATE: \_\_\_\_\_

**CONTAINMENT SOLUTIONS**

DRAWN BY: D. ROVANG	DATE DRAWN: 01-01-14
DWG NUMBER: 5104284	SCALE: 1:36
REV: _____	REV BY: _____
DATE: _____	SHEET: 1 OF 1