

**NOTE:**  
 OVERALL SHIPPING DIMENSION: 6'-11" L X 2'-5" W X 4'-2" H

ITEM	SIZE	SUGGESTED FUNCTION
1	3"	EFFLUENT
2	2"	INFLUENT
3	3"	TRANSFER PIPE
4		COALESCER
5		DEBRIS PLATES
6	2" X 12"	OIL EQUALIZING ORIFICE
7		COVER, DWG."CVB002"
8	2"	SECONDARY WORKING VENT
9	4"	SECONDARY CONTAINMENT EMERGENCY VENT
10	1"	FLOAT SENSOR NPT FTG.
11	2"	OIL DRAW W/PIPE

**TANK SPECIFICATIONS**  
 MATERIAL: PRIMARY TANK - 10 GA.

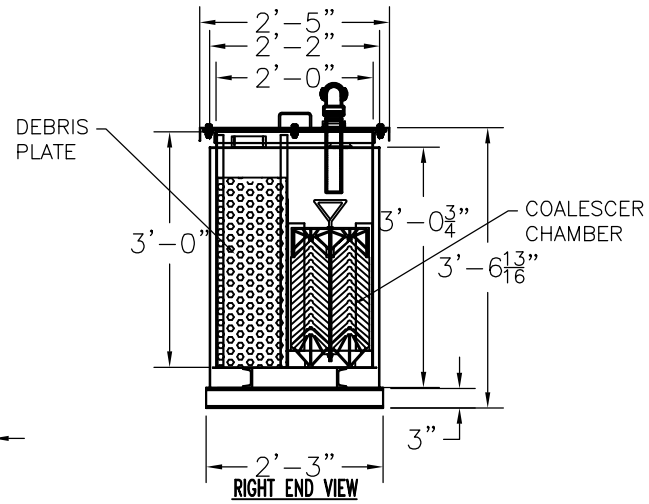
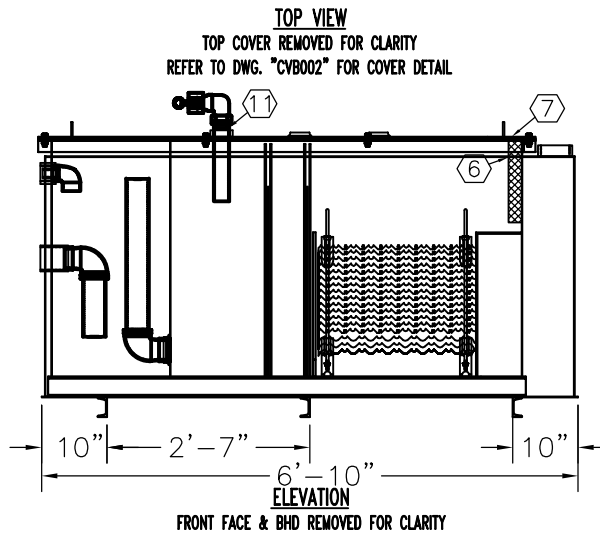
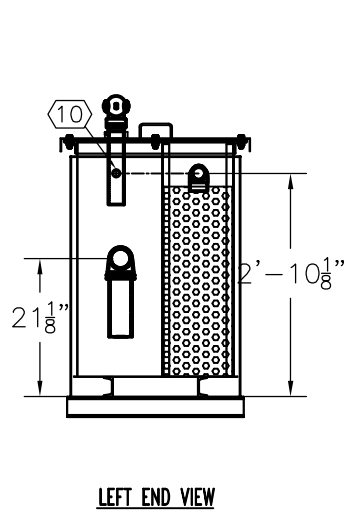
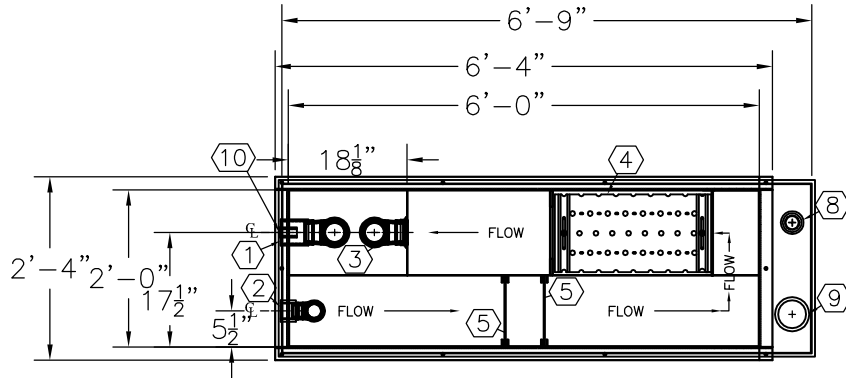

PRODUCT CODE	GALLONS	DESCRIPTION	OVERALL SIZE	SHIP WT.
WSAA1250DS000	250	DOUBLE WALL OIL WATER SEPARATOR (25 GPM)	6'-10" L X 2'-3" W X 3'-7" H	1,400 LBS.

THIS DRAWING AND DESIGN SHOWN HEREIN IS THE PROPERTY OF CONTAINMENT SOLUTIONS. USE OR COPIES THEREOF CANNOT BE MADE WITHOUT WRITTEN CONSENT.

CUSTOMER NAME: \_\_\_\_\_  
**APPROVED** BY: \_\_\_\_\_ DATE: \_\_\_\_\_

**CONTAINMENT SOLUTIONS**

DRAWN BY: \_\_\_\_\_ DATE DRAWN: 01-01-14  
 DWG NUMBER: 5100268 SCALE: 1:30  
 REV: \_\_\_\_\_ REV BY: \_\_\_\_\_ DATE: \_\_\_\_\_ SHEET: 1 OF 1