

ITEM	SIZE	SUGGESTED FUNCTION
1	2"	OIL PUMP OUT
2	2"	SENSOR/SPARE
3	2"	WORKING VENT

**SPECIFICATIONS**  
**MATERIAL: COVER - 10 GA.**

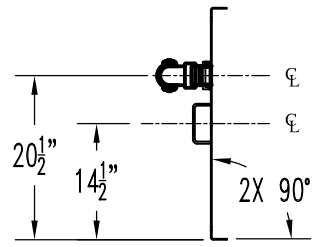

**SIDE VIEW**

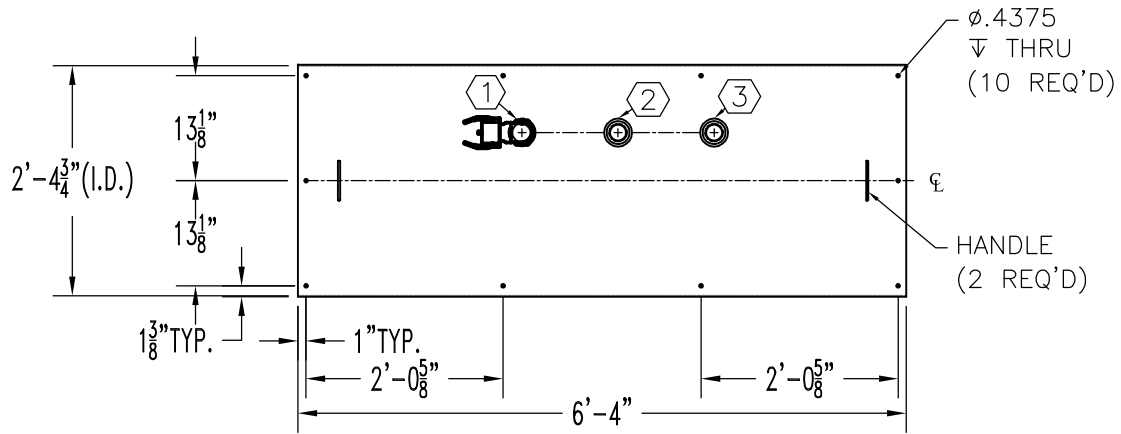
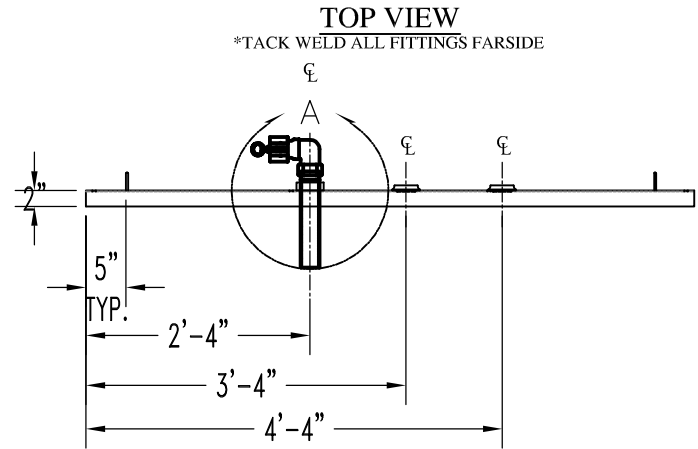

**ELEVATION**

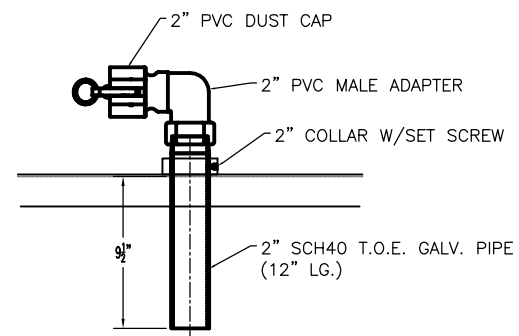

**DETAIL A**  
**SCALE 1:6**

**TOP VIEW**  
 \*TACK WELD ALL FITTINGS FARSIDE

PRODUCT CODE	GALLONS	DESCRIPTION	OVERALL SIZE	SHIP WT.
CVB002	250	COVER FOR OIL WATER SEPARATOR (25 GPM)	5'-11" L X 2'-5" W X 2" H	

THIS DRAWING AND DESIGN SHOWN HEREIN IS THE PROPERTY OF CONTAINMENT SOLUTIONS. USE OR COPIES THEREOF CANNOT BE MADE WITHOUT WRITTEN CONSENT.

CUSTOMER NAME: \_\_\_\_\_  
**APPROVED** BY: \_\_\_\_\_ DATE: \_\_\_\_\_

**CONTAINMENT SOLUTIONS®**

DRAWN BY: D. ROVANG      DATE DRAWN: 01-01-14  
 DWG NUMBER: CVB002      SCALE: 1:32  
 REV:      REV BY:      DATE:      SHEET: 1 OF 1