

NOTE:

OVERALL SHIPPING DIMENSION: 17'-11" L X 5'-5" W X 5'-2" H

ITEM	SIZE	SUGGESTED FUNCTION
1	8"	EFFLUENT
2	8"	INFLUENT
3	8"	TRANSFER PIPE
4		COALESCER
5		DEBRIS PLATES
6	2" X 18"	OIL EQUALIZING ORIFICE
7		COVER, DWG."CVB007"
8	2"	SECONDARY WORKING VENT
9	4"	SECONDARY CONTAINMENT EMERGENCY VENT
10	1"	FLOAT SENSOR NPT FTG.
11	2"	OIL DRAW W/PIPE

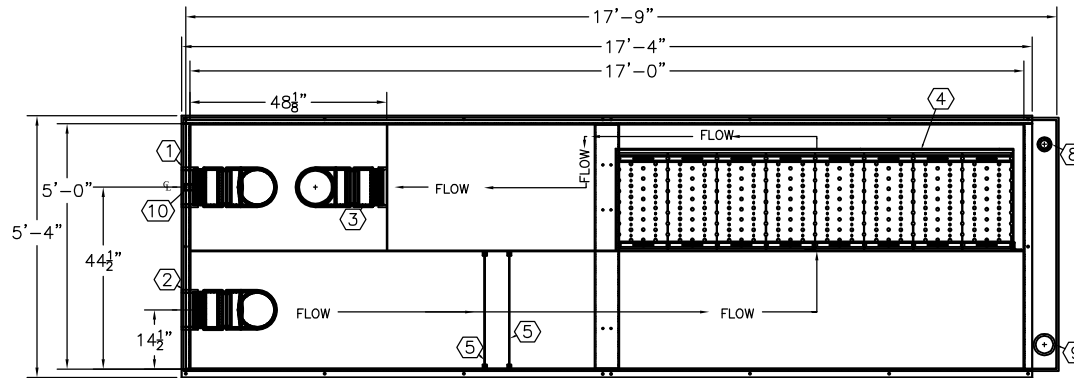

TOP VIEW

TOP COVER REMOVED FOR CLARITY
REFER TO DWG. "CVB007" FOR COVER DETAIL

TANK SPECIFICATIONS

MATERIAL: PRIMARY TANK - 3/16" THK.

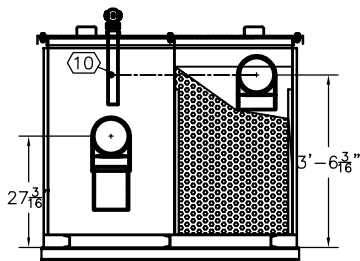

LEFT END VIEW

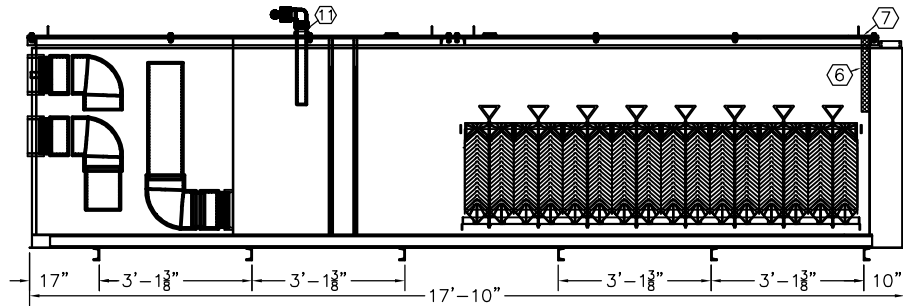

ELEVATION
FRONT FACE & BHD REMOVED FOR CLARITY

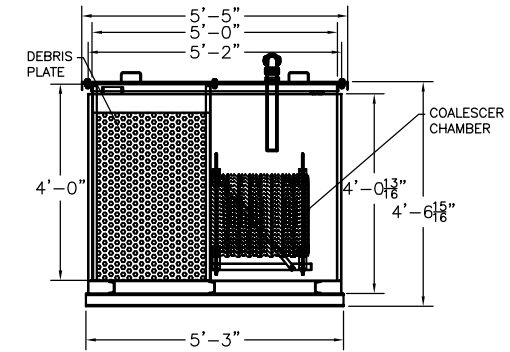

RIGHT END VIEW

PRODUCT CODE	GALLONS	DESCRIPTION	OVERALL SIZE	SHIP WT.
WSAA125CDS000	2,500	DOUBLE WALL OIL WATER SEPARATOR (250 GPM)	17'-10" L X 5'-3" W X 4'-7" H	8,025 LBS.

THIS DRAWING AND DESIGN SHOWN HEREIN IS THE PROPERTY OF CONTAINMENT SOLUTIONS. USE OR COPIES THEREOF CANNOT BE MADE WITHOUT WRITTEN CONSENT.

CUSTOMER NAME: _____

APPROVED BY: _____ DATE: _____



DRAWN BY: D. ROVANG	DATE DRAWN: 01-01-14
DWG NUMBER: 5100273	SCALE: 1:48
REV: _____	REV BY: _____
DATE: _____	SHEET: 1 OF 1