

**NOTE:**

OVERALL SHIPPING DIMENSION: 17'-4" L X 5'-5" W X 4'-11" H

ITEM	SIZE	SUGGESTED FUNCTION
1	8"	EFFLUENT
2	8"	INFLUENT
3	8"	TRANSFER PIPE
4		COALESCER
5		DEBRIS PLATES
6	2" X 18"	OIL EQUALIZING ORIFICE
7		COVER, DWG."CVB007"
8	1"	FLOAT SENSOR NPT FTG.
9	2"	OIL DRAW W/PIPE

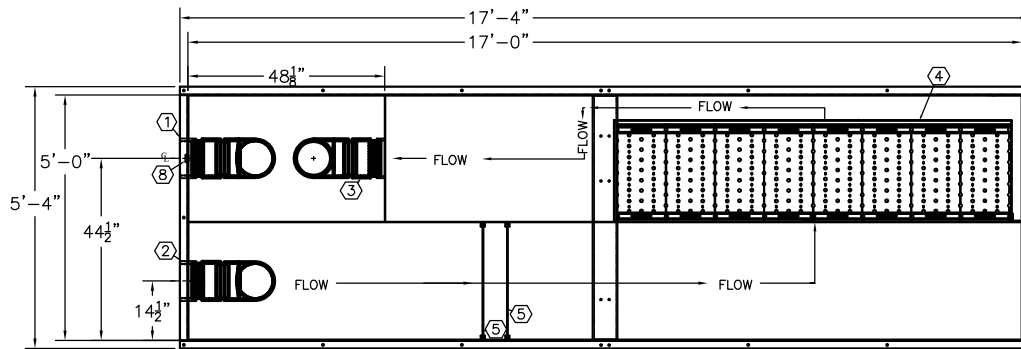

**TOP VIEW**

TOP COVER REMOVED FOR CLARITY  
REFER TO DWG. "CVB007" FOR COVER DETAIL

**TANK SPECIFICATIONS**

MATERIAL: PRIMARY TANK - 3/16" THK.

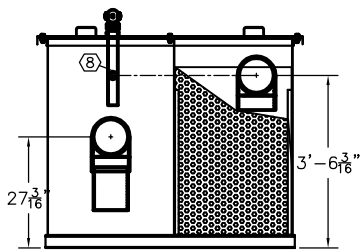

**LEFT END VIEW**

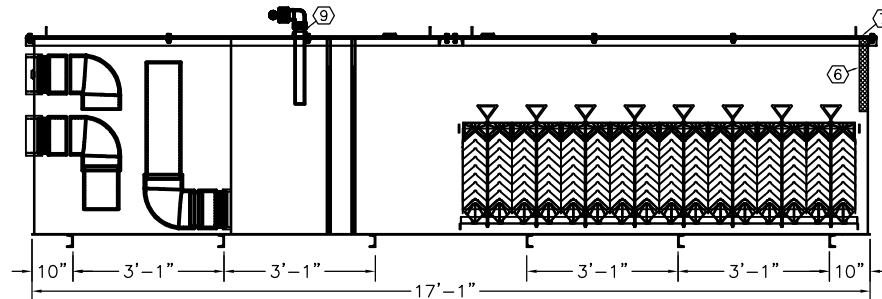

**ELEVATION**

FRONT FACE & BHD REMOVED FOR CLARITY

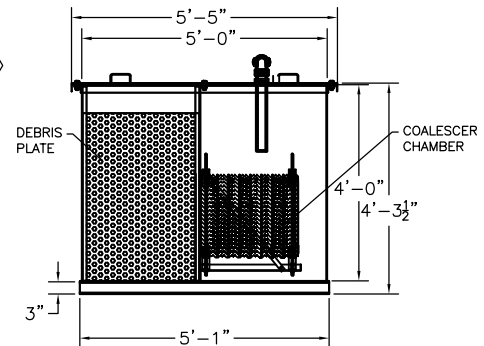

**RIGHT END VIEW**

PRODUCT CODE	GALLONS	DESCRIPTION	OVERALL SIZE	SHIP WT.
WSAA125CSS000	2,500	SINGLE WALL OIL WATER SEPARATOR (250 GPM)	17'-1" L X 5'-1" W X 4'-4" H	4,475 LBS.

THIS DRAWING AND DESIGN SHOWN HEREIN IS THE PROPERTY OF CONTAINMENT SOLUTIONS. USE OR COPIES THEREOF CANNOT BE MADE WITHOUT WRITTEN CONSENT.

CUSTOMER NAME \_\_\_\_\_

**APPROVED** BY: \_\_\_\_\_ DATE: \_\_\_\_\_

**CONTAINMENT SOLUTIONS**

DRAWN BY:	DATE DRAWN: 01-01-14
DWG NUMBER: 5100266	SCALE: 1:48
REV:	REV BY: DATE: SHEET: 1 OF 1