

**NOTE:**  
 OVERALL SHIPPING DIMENSION: 10'-11" L X 3'-11" W X 4'-2" H

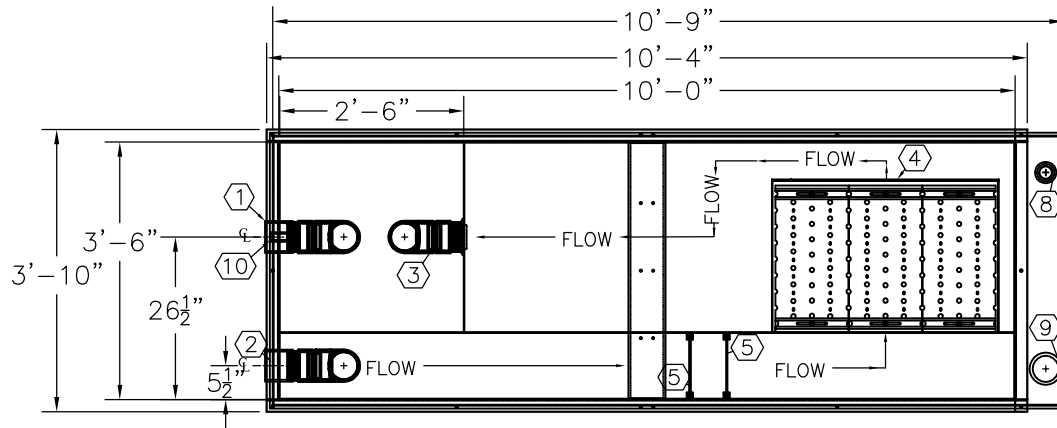

ITEM	SIZE	SUGGESTED FUNCTION
1	4"	EFFLUENT
2	4"	INFLUENT
3	4"	TRANSFER PIPE
4		COALESCER
5		DEBRIS PLATES
6	2" X 6"	OIL EQUALIZING ORIFICE
7		COVER, DWG."CVB004"
8	2"	SECONDARY WORKING VENT
9	4"	SECONDARY CONTAINMENT EMERGENCY VENT
10	1"	FLOAT SENSOR NPT FTG.
11	2"	OIL DRAW W/PIPE

**TANK SPECIFICATIONS**  
 MATERIAL: PRIMARY TANK - 10 GA.

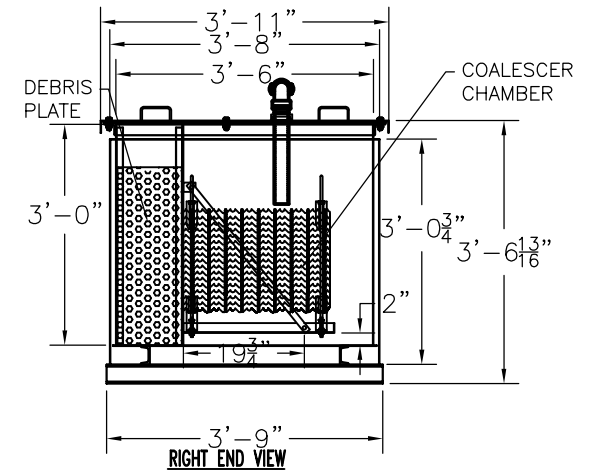
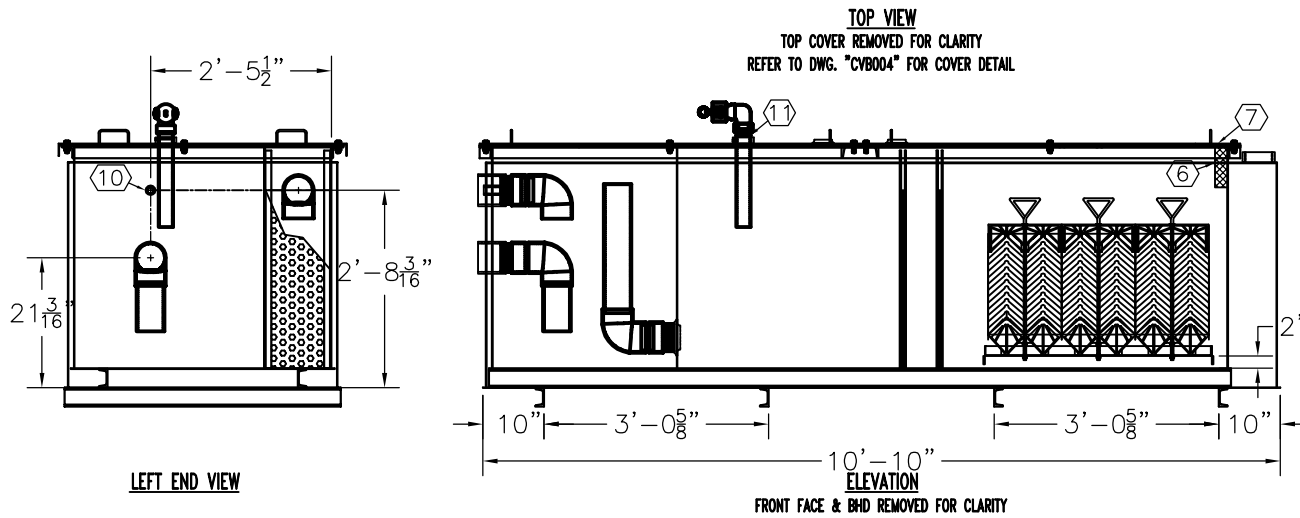

PRODUCT CODE	GALLONS	DESCRIPTION	OVERALL SIZE	SHIP WT.
WSAA1750DS000	750	DOUBLE WALL OIL WATER SEPARATOR (75 GPM)	10'-10" L X 3'-9" W X 3'-7" H	3,350 LBS.

THIS DRAWING AND DESIGN SHOWN HEREIN IS THE PROPERTY OF CONTAINMENT SOLUTIONS. USE OR COPIES THEREOF CANNOT BE MADE WITHOUT WRITTEN CONSENT.

CUSTOMER NAME: \_\_\_\_\_  
**APPROVED** BY: \_\_\_\_\_ DATE: \_\_\_\_\_

**CONTAINMENT SOLUTIONS**

DRAWN BY: \_\_\_\_\_ DATE DRAWN: 01-01-14  
 DWG NUMBER: 5100270 SCALE: 1:32  
 REV: \_\_\_\_\_ REV BY: \_\_\_\_\_ DATE: \_\_\_\_\_ SHEET: 1 OF 1