

NOTE:
OVERALL SHIPPING DIMENSION: 5'-8" L X 2'-9" W X 3'-1" H

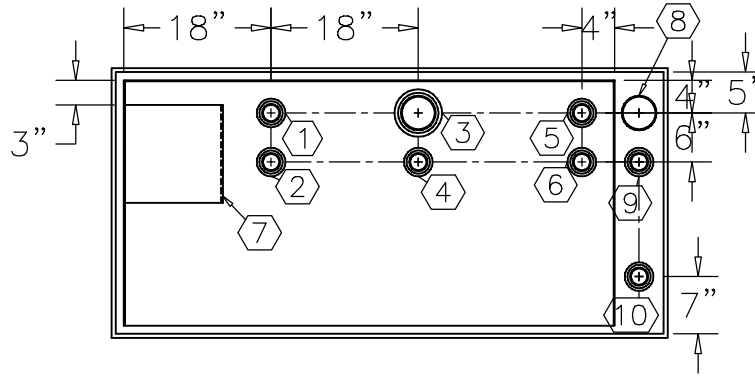

TOP VIEW

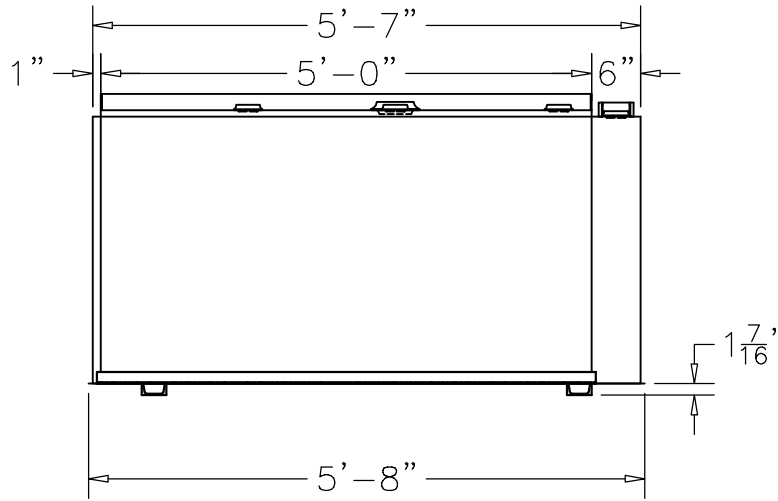

ELEVATION

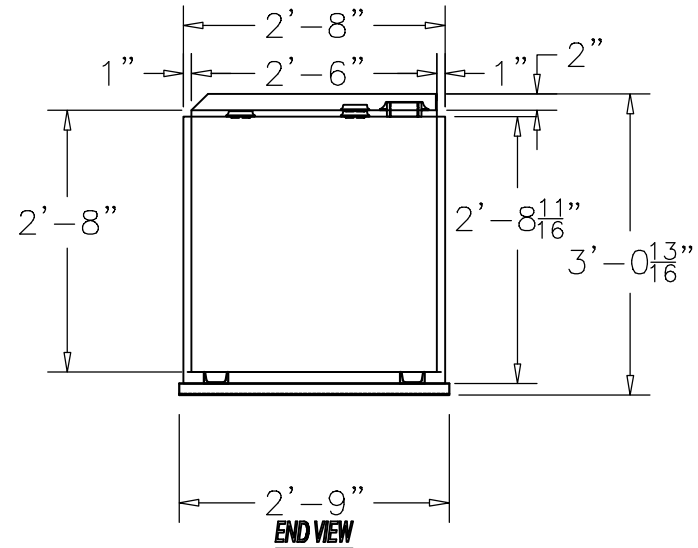

END VIEW

ITEM	SIZE	SUGGESTED FUNCTION
1	2"	PUMP SUPPLY
2	2"	SPARE
3	4"	PRIMARY TANK EMERGENCY VENT
4	2"	MECHANICAL GAUGE/ SPARE
5	2"	PRIMARY TANK WORKING VENT
6	2"	FILL
7	12" X 12"	PUMP BRACKET, DWG."PBB002"
8	4"	SECONDARY CONTAINMENT EMERGENCY VENT
9	2"	SECONDARY MONITOR PORT/ SPARE
10	2"	SECONDARY WORKING VENT

TANK SPECIFICATIONS

VENTING CAPACITY: PRIMARY TANK - 63,200 CUBIC FEET PER HOUR
 SECONDARY TANK - 63,200 CUBIC FEET PER HOUR
 MATERIAL: PRIMARY TANK - 10 GA.
 SECONDARY TANK - 10 GA.

PRODUCT CODE	GALLONS	DESCRIPTION	OVERALL SIZE	SHIP WT.
BTAA1240DS000	240	UL-142 DOUBLE WALL BENCHTOP TANK	5'-8" L X 2'-9" W X 3'-1" H	900 LBS.

THIS DRAWING AND DESIGN SHOWN HEREIN IS THE PROPERTY OF CONTAINMENT SOLUTIONS. USE OR COPIES THEREOF CANNOT BE MADE WITHOUT WRITTEN CONSENT.

CUSTOMER NAME: _____
APPROVED BY: _____ DATE: _____



DRAWN BY: D. ROVANG	DATE DRAWN: 01-01-14
DWG NUMBER: 5100241	SCALE: 1:24
REV: _____	REV BY: _____
DATE: _____	SHEET: 1 OF 1