

**NOTE:**  
 OVERALL SHIPPING DIMENSION: 6'-8" L X 4'-5" W X 3'-1" H

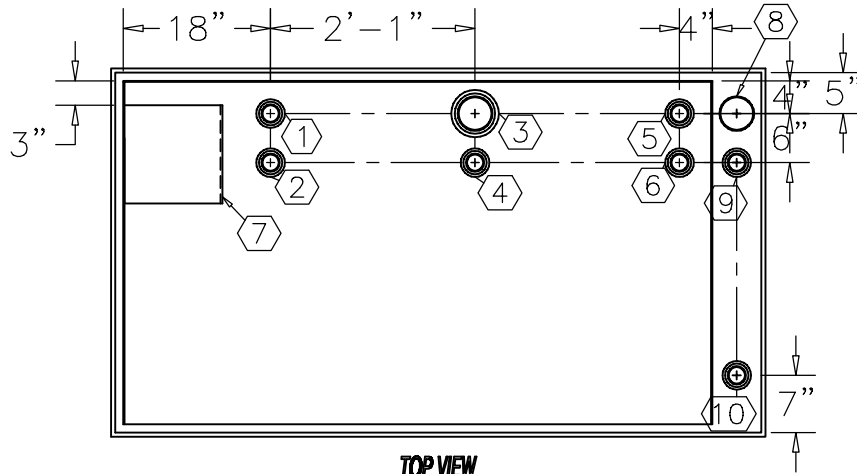

**TOP VIEW**

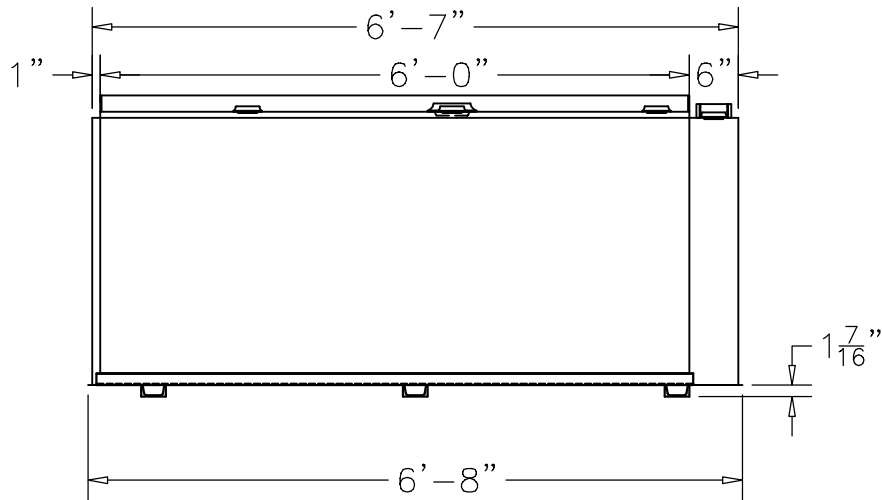

**ELEVATION**

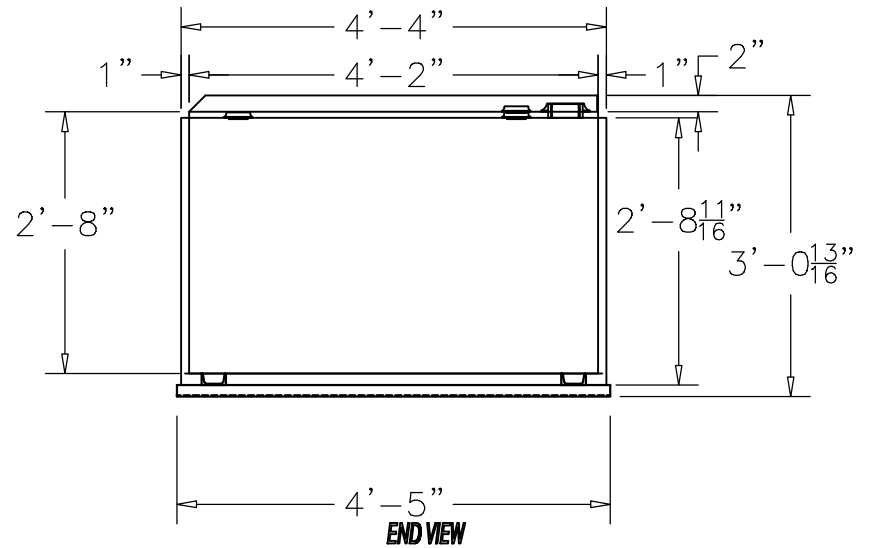

**END VIEW**

ITEM	SIZE	SUGGESTED FUNCTION
1	2"	PUMP SUPPLY
2	2"	SPARE
3	4"	PRIMARY TANK EMERGENCY VENT
4	2"	MECHANICAL GAUGE/ SPARE
5	2"	PRIMARY TANK WORKING VENT
6	2"	FILL
7	12" X 12"	PUMP BRACKET, DWG."PBB002"
8	4"	SECONDARY CONTAINMENT EMERGENCY VENT
9	2"	SECONDARY MONITOR PORT/ SPARE
10	2"	SECONDARY WORKING VENT

**TANK SPECIFICATIONS**

VENTING CAPACITY: PRIMARY TANK - 84,200 CUBIC FEET PER HOUR  
 SECONDARY TANK - 94,800 CUBIC FEET PER HOUR  
 MATERIAL: PRIMARY TANK - 10 GA.  
 SECONDARY TANK - 10 GA.

PRODUCT CODE	GALLONS	DESCRIPTION	OVERALL SIZE	SHIP WT.
BTAA1500DS000	500	UL-142 DOUBLE WALL BENCHTOP TANK	6'-8" L X 4'-5" W X 3'-1" H	1,325 LBS.
THIS DRAWING AND DESIGN SHOWN HEREIN IS THE PROPERTY OF CONTAINMENT SOLUTIONS. USE OR COPIES THEREOF CANNOT BE MADE WITHOUT WRITTEN CONSENT.				
CUSTOMER NAME	APPROVED BY: _____		DATE: _____	

**CONTAINMENT SOLUTIONS®**

DRAWN BY: D. ROVANG	DATE DRAWN: 01-01-14
DWG NUMBER: 5100244	SCALE: 1:24
REV: _____	REV BY: _____
DATE: _____	SHEET: 1 OF 1