

NOTE:
 OVERALL SHIPPING DIMENSION: 5'-1" L X 2'-7" W X 3'-11" H

ITEM	SIZE	SUGGESTED FUNCTION
1	2"	PUMP SUPPLY
2	2"	SPARE
3	4"	PRIMARY TANK EMERGENCY VENT
4	2"	MECHANICAL GAUGE/ SPARE
5	2"	PRIMARY TANK WORKING VENT
6	2"	FILL
7	1/2"	DRAIN FOR SPILLBOX
8	7 GAL.	SPILLBOX, DWG."SBB002"
9	12" X 12"	PUMP BRACKET, DWG."PBB002"

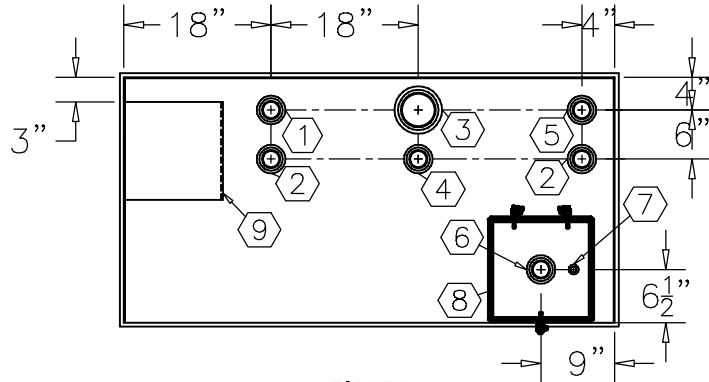

TOP VIEW

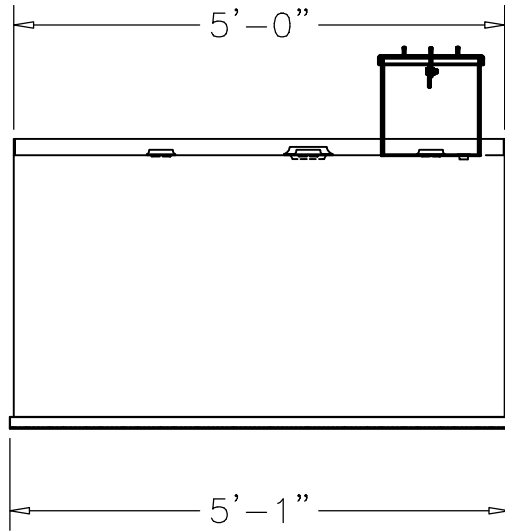

ELEVATION

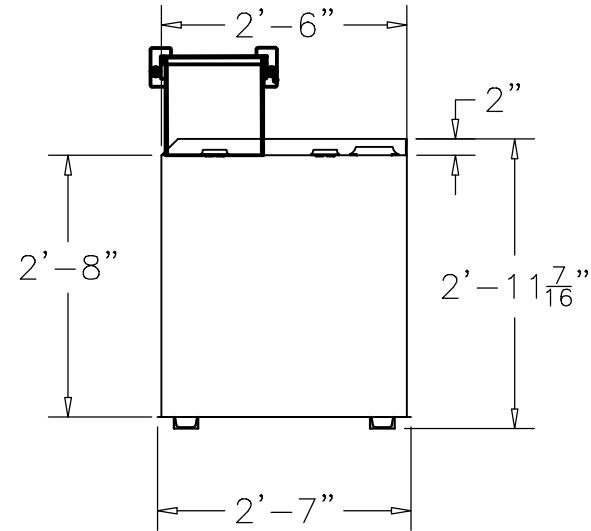

END VIEW

TANK SPECIFICATIONS

VENTING CAPACITY: PRIMARY TANK - 63,200 CUBIC FEET PER HOUR
 MATERIAL: PRIMARY TANK - 10 GA.

PRODUCT CODE	GALLONS	DESCRIPTION	OVERALL SIZE	SHIP WT.
BTAA1240SS001	240	UL-142 SINGLE WALL BENCHTOP TANK W/SPILLBOX	5'-1" L X 2'-7" W X 3'-0" H	530 LBS.

THIS DRAWING AND DESIGN SHOWN HEREIN IS THE PROPERTY OF CONTAINMENT SOLUTIONS. USE OR COPIES THEREOF CANNOT BE MADE WITHOUT WRITTEN CONSENT.

CUSTOMER NAME: _____
APPROVED BY: _____ DATE: _____

CONTAINMENT SOLUTIONS®

DRAWN BY: D. ROVANG DATE DRAWN: 01-01-14
 DWG NUMBER: 5100236 SCALE: 1:24
 REV: REV BY: DATE: SHEET: 1 OF 1