

**NOTE:**  
 OVERALL SHIPPING DIMENSION: 6'-7" L X 3'-7" W X 3'-0" H

ITEM	SIZE	SUGGESTED FUNCTION
1	2"	PUMP SUPPLY
2	2"	SPARE
3	4"	PRIMARY TANK EMERGENCY VENT
4	2"	MECHANICAL GAUGE/ SPARE
5	2"	PRIMARY TANK WORKING VENT
6	2"	FILL
7	12" X 12"	PUMP BRACKET, DWG."PBB002"

**TANK SPECIFICATIONS**

VENTING CAPACITY: PRIMARY TANK - 84,200 CUBIC FEET PER HOUR  
 MATERIAL: PRIMARY TANK - 10 GA.

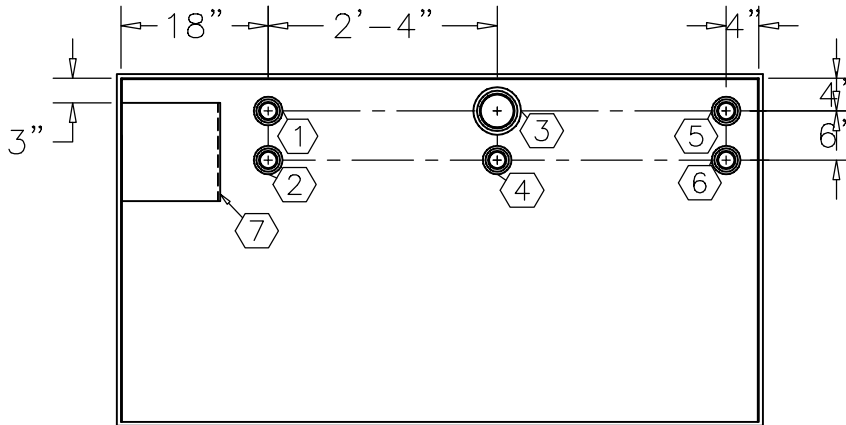

**TOP VIEW**

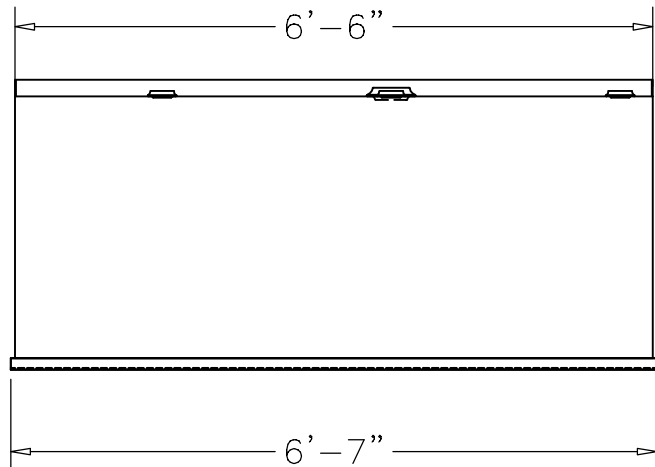

**ELEVATION**

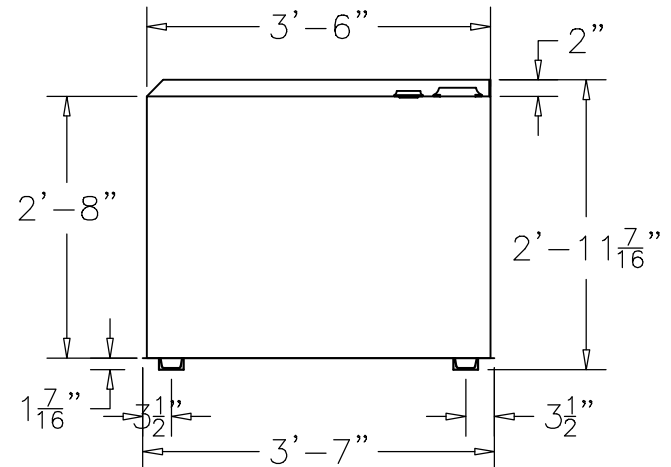

**END VIEW**

PRODUCT CODE	GALLONS	DESCRIPTION	OVERALL SIZE	SHIP WT.
BTAA1450SS000	450	UL-142 SINGLE WALL BENCHTOP TANK	6'-7" L X 3'-7" W X 3'-0" H	725 LBS.

THIS DRAWING AND DESIGN SHOWN HEREIN IS THE PROPERTY OF CONTAINMENT SOLUTIONS. USE OR COPIES THEREOF CANNOT BE MADE WITHOUT WRITTEN CONSENT.

CUSTOMER NAME: \_\_\_\_\_

**APPROVED** BY: \_\_\_\_\_ DATE: \_\_\_\_\_



DRAWN BY: D. ROVANG		DATE DRAWN: 01-01-14	
DWG NUMBER: 5100233		SCALE: 1:24	
REV:	REV BY:	DATE:	SHEET: 1 OF 1