

NOTE:
OVERALL SHIPPING DIMENSION: 9'-8" L X 3'-1" W X 3'-2" H

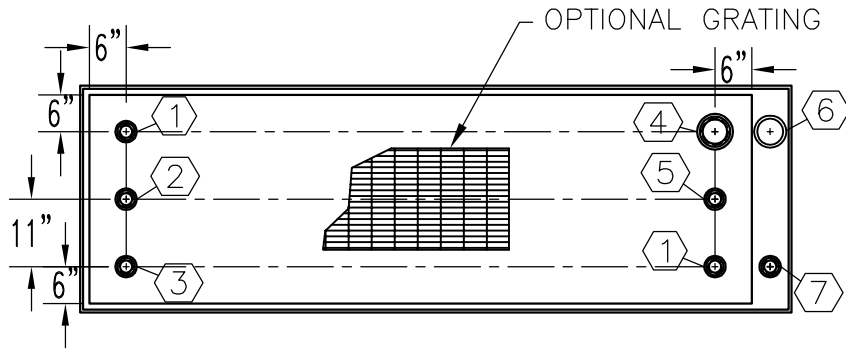

TOP VIEW

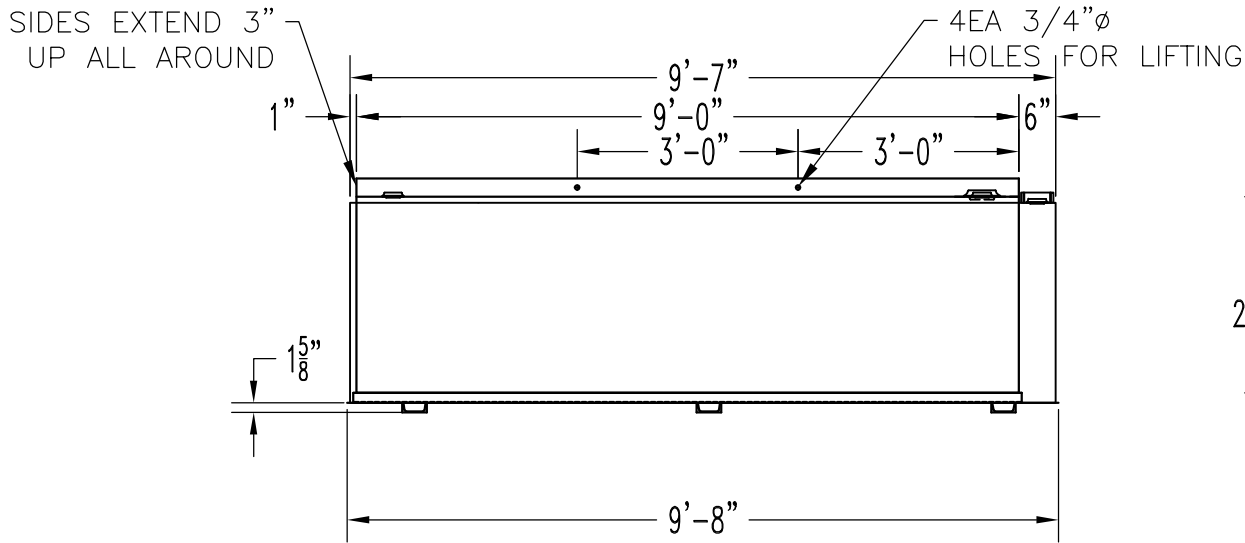

ELEVATION VIEW

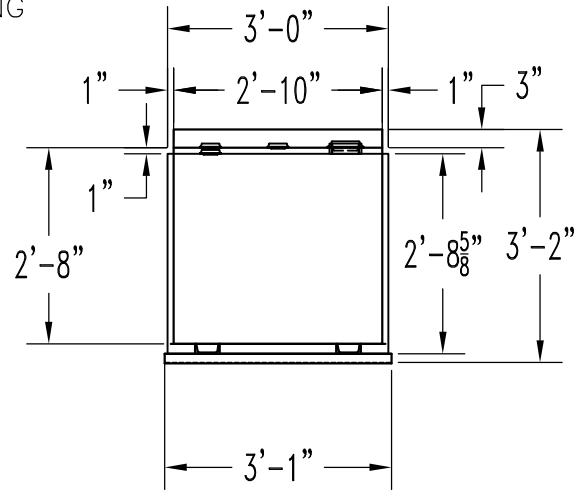

END VIEW

ITEM	SIZE	SUGGESTED FUNCTION
1	2"	SPARE
2	2"	MECHANICAL GAUGE/ SPARE
3	2"	FILL
4	4"	PRIMARY TANK EMERGENCY VENT
5	2"	PRIMARY TANK WORKING VENT
6	4"	SECONDARY CONTAINMENT EMERGENCY VENT
7	2"	SECONDARY WORKING VENT

TANK SPECIFICATIONS

VENTING CAPACITY: PRIMARY-94,800 CUBIC FEET PER HOUR
 SECONDARY-105,000 CUBIC FEET PER HOUR
MATERIAL: PRIMARY TANK - 3/16" THK.
 SECONDARY TANK - 10 GA.

PRODUCT CODE	GALLONS	DESCRIPTION	OVERALL SIZE	SHIP WT.
CWAA1500DS000	500	UL-142 DOUBLE WALL CATWALK TANK	9'-8" L X 3'-1" W X 3'-2" H	2,000 LBS.
THIS DRAWING AND DESIGN SHOWN HEREIN IS THE PROPERTY OF CONTAINMENT SOLUTIONS. USE OR COPIES THEREOF CANNOT BE MADE WITHOUT WRITTEN CONSENT.				
CUSTOMER NAME		APPROVED BY: _____		DATE: _____

CONTAINMENT SOLUTIONS

DRAWN BY: D. ROVANG DATE DRAWN: 01-01-14
 DWG NUMBER: 5100224 SCALE: 1:32
 REV: REV BY: DATE: SHEET: 1 OF 1