

FIBERGLASS MANHOLE

INSTALLATION INSTRUCTIONS
& OPERATING GUIDELINES



CONTAINMENT
SOLUTIONS®

- 1. Introduction2
- 2. Selecting Height3
- 3. Handling and Preparation3
- 4. Flowlines and Laterals4
- 5. Site Preparation.....4
- 6. Manhole Positioning5
- 7. Bottom Slab for Open Bottom Manholes5
- 8. Closed Bottom Manholes
with Factory Supplied Bottom Slab5
- 9. Bottom Slab For Closed Bottom Manholes
without External Structural Anchors6
- 10. Bottom Slab for Closed Bottom Manholes
with External Structural Anchors6
- 11. Bed and Backfill7
- 12. Manhole Installation with FRP Tank.....7
- 13. Adhesive Channel Instructions7
- 14. Finishing Manhole to Grade8
- 15. Flexible Boot Installation9
- 16. Operating Guidelines.....9

- Appendix A - Manholes WITHOUT external Anchors10
- Appendix B - Manholes WITH external Anchors12
- Appendix C - Backfill & Compaction Tables.....14

Field Service Dept. Mt. Union, Pennsylvania (800) 822-1997 (814) 542-8520	Technical Support Conroe, Texas (877) 274-8265 (936) 756-7731
--	--

1. INTRODUCTION

- 1.1. Containment Solutions (CSI) Fiberglass Manholes are of one-piece construction, incorporating a fiberglass cylinder, or barrel, and a reducer.
- 1.2. CSI manholes are built to ASTM Standard D-3753 "Standard Specification of Glass-Fiber Reinforced Polyester Manholes and Wetwells."
- 1.3. Products are available up to 10' diameter. The reducer at the top is available with an I.D. of 22½", 31¾", or 38" concentrically positioned or 22½" eccentrically positioned.
- 1.4. Manhole heights range from 3' - 50', in half foot increments. When ordering manholes, specify each unit needed by height.
- 1.5. The following instructions reflect the approved methods for installing manholes.

1.6. Safety

- 1.6.1. These instructions should not be interpreted in any way to put one's health at risk, or to harm property and/or the environment.
- 1.6.2. The following definitions will serve as a guide when reading this manual:

⚠ WARNING

Indicates a potentially hazardous situation, which if not avoided could result in death or serious injury.

⚠ CAUTION

Indicates a potentially hazardous situation, which if not avoided may result in minor or moderate injury.

NOTICE

Indicates a potentially hazardous situation, which if not avoided may result in property damage.

1.7. Important Information

- 1.7.1. Proper installation of each manhole is essential to ensure the safety of all the individuals involved in the installation; to prevent manhole damage and/or failure, which could lead to product loss and environmental contamination; and to validate the manhole warranty.
- 1.7.2. Containment Solutions fiberglass manholes must be installed according to these published instructions (MAN 4033) as well as any required supplemental instructions.
- 1.7.3. Follow all OSHA, Federal, State, Local or Provincial safety and environmental codes and regulations.

⚠ WARNING

Manholes are a confined space per OSHA guidelines. Follow proper confined space safety procedures.

1.8. Manhole Warranty Activation

- 1.8.1. These instructions must be followed.
- 1.8.2. Any variances or deviations which are in direct conflict with these published installation instructions must be approved in writing by CSI prior to the installation.
- 1.8.3. Any written authorization related to the manhole installation must be retained by the owner and provided later to CSI to validate any future warranty claim.
- 1.8.4. The warranty in effect at the time of delivery will apply and is available from Containment Solutions.

1.9. Before You Begin

- 1.9.1. Read, understand and follow these instructions.
- 1.9.2. Barricade the work area.
- 1.9.3. If you have questions on other manhole installation details, call Technical Support at 800-537-4730.

2. SELECTING HEIGHT

- 2.1. To determine the ordering height of an open bottom manhole, first measure the distance from the bottom of the pipe (the flowline) to finished grade. This measurement is the Y value.
- 2.2. Subtract 1', (12") from the Y value. This will allow sufficient clearance for at least one course of brick (or one concrete ring) to adjust the cast-iron ring and cover to finish grade.
- 2.3. Then add a minimum of 4". This is the distance between the flowline and the manhole bottom.
- 2.4. Round the total measurement to the next greatest half foot, (6"), to find the manhole ordering height (See Figure 2-1).

NOTE: Closed bottom manholes are custom ordered per specifications.

Figure 2-1

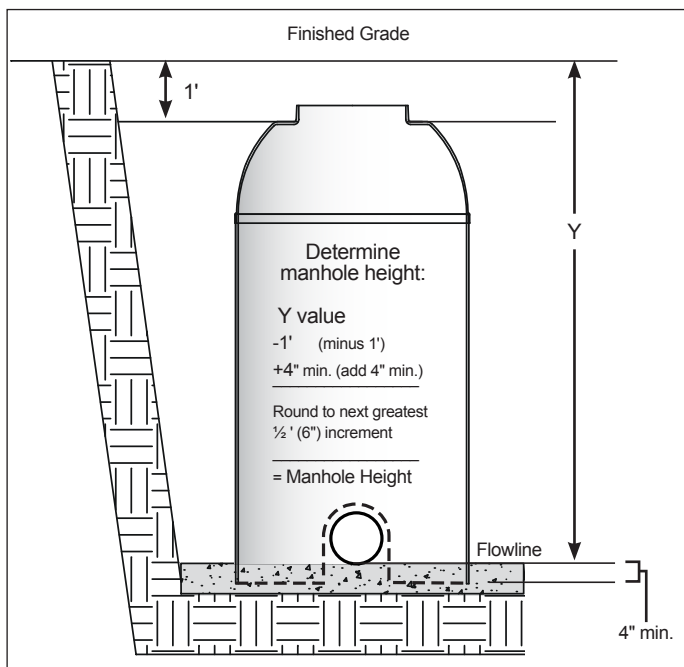

3. HANDLING & PREPARATION

⚠ WARNING

Do not stand on or under manhole while it is being lifted. This could result in injury or death.

⚠ WARNING

Do not allow driver to release straps securing the manhole to the truck until the manhole is safe to offload. Failure to do so could result in death or serious injury.

- 3.1. Upon manhole delivery and when lifting manhole, visually inspect entire exterior surface for shipping or handling damage.
- 3.2. If damage exists, contact CSI prior to installation.
- 3.3. Do not drop or impact the manhole.
- 3.4. Open bottom manholes should be stored horizontally and chocked, using only appropriate materials such as sandbags, tires, or other soft or pliable materials.

- 3.5. Do not roll or set the manhole on any pipe stubout, accessory or appurtenance installed on the manhole.
- 3.6. The contractor is responsible for rigging, unloading and securing the manhole.
- 3.7. Always lift, never roll, slide or push a manhole.
- 3.8. When lifting the manhole in the horizontal position, use two slings with a spreader bar.
- 3.9. Only a pliable strap or rope should contact the manhole, do not use chains, steel cables or hard metallic slings.
- 3.10. Do not wrap chain or cable around the manhole.
- 3.11. For 42", 48" and 60" diameter manholes with 24" opening and up to 20' length, use a 4"x4" timber inserted through the top access opening for vertical positioning. Timber should be 8 inches (8") longer than the manhole opening. All other manholes should be offloaded with slings or in some instances, lifting lugs. (see Figure 3-1).

Figure 3-1

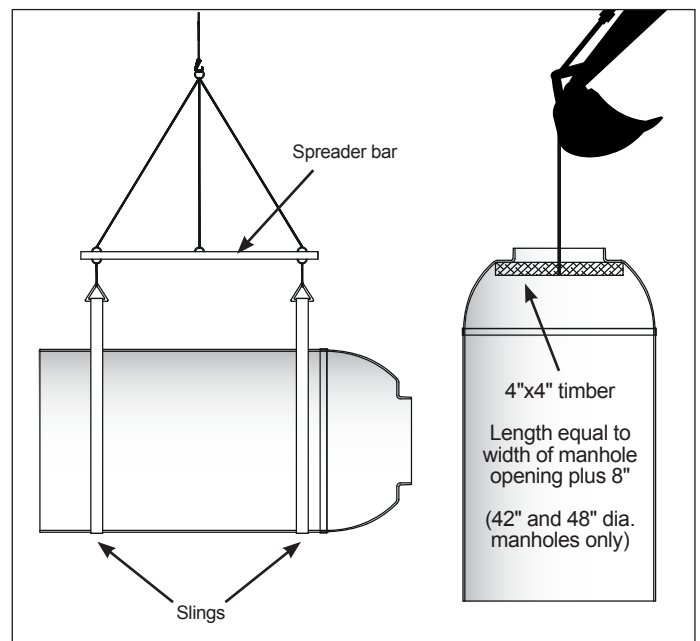

- 3.12. Larger manholes are rotated on the truck for shipping purposes. These manholes may have lifting lug(s) to aid in the loading/unloading process.
- 3.13. Larger manholes may have lifting lugs that are situated on top of the manhole in its rotated position. Use a minimum of two lift lugs when pivoting the manhole from horizontal to vertical.
- 3.14. To install manholes with lift lugs, carefully rotate the manhole to its upright position and then use all lifting lugs situated on top of the manhole in its upright position.

4. FLOWLINES & LATERALS

⚠ WARNING

To prevent fire or explosion hazard, Containment Solutions recommends air driven tools whenever possible. Do not use electrical power tools where flammable vapors or liquids exist. Also, when electric hand tools are used, be aware of potential shock hazards. Wear protective clothing and eye protection.



ASPHYXIATION



FIRE



EXPLOSION

⚠ CAUTION

Always wear safety glasses and protective clothing when cutting on the manhole, failure to do so can result in personal injury.

4.1. Cutting the Flowline (Doghouse Cut)

4.1.1. Quarter marks have been provided on barrel to facilitate alignment of cutouts. The size of the flowline cutout is determined as follows:

- Maximum single cutout diameter is 77% of manhole diameter (Ex: 37" for 48" diameter)
- Sum of all cutout diameters not to exceed 156% of manhole diameter
- Minimum distance between cutouts is 12".
- Height of cutout shall be sufficient to insure that the top of manhole cone when set in place will be below finish grade, to allow for final adjustment of chimney ring and cover.
- Height of cutout should be deep enough to insure that a minimum of 4" of manhole base will penetrate concrete slab.
- Using the proper equipment, make cutout conform as closely as possible to pipe O.D. plus 1/2" (See Figure 4-1).

Figure 4-1

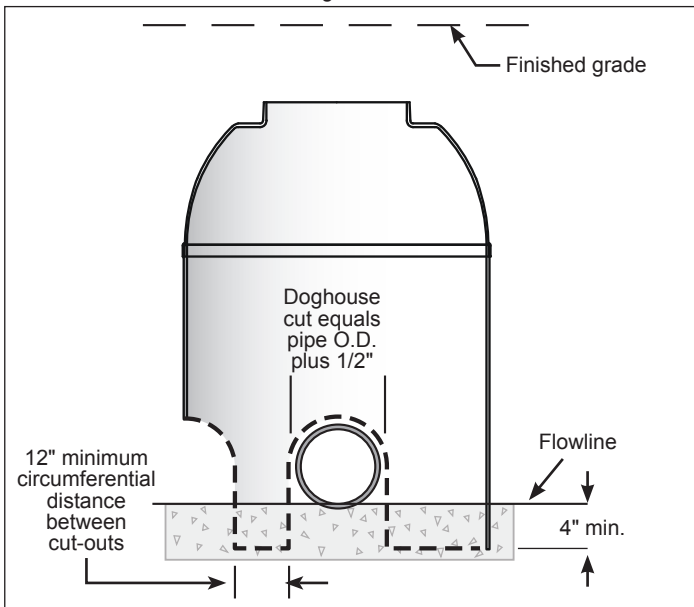

- Pipe cutouts for flowlines are made in the manhole barrel prior to setting manhole in place over the pipe in the trench.
- Use proper equipment and appropriate saw blades (typically diamond or carbide) when making any cuts or modifications to the manhole structure. Never use an axe or other impact type tool.
- Pipe penetration cutouts should be round holes and should be no larger than the pipe diameter plus 1".

4.2. Inverts and Laterals

4.2.1. The invert should be constructed according to the engineer's specifications.

- If laterals are needed, standard drops should be used.
- Using the proper equipment, make cutout conform as closely as possible to pipe O.D. plus 1/2" (see Figure 4-2).

Figure 4-2

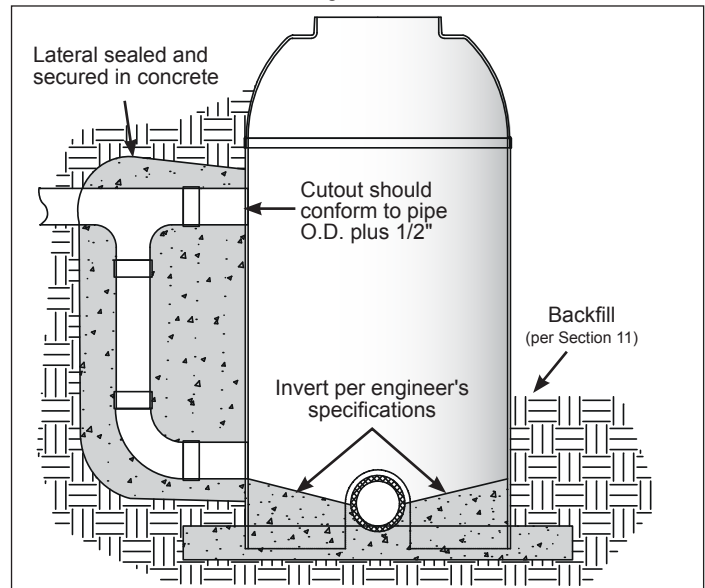

5. SITE PREPARATION

- 5.1. Dimensions of the excavation should be wide enough to provide sufficient working room around the manhole.
- 5.2. Use minimum 3000-psi concrete for bottom slabs. Final slab depth, size, thickness and reinforcements shall meet the minimum requirements in these instructions and applicable tables, including appendix.
- 5.3. Slabs should extend at least 12" beyond the O.D. of the manhole.
- 5.4. All pipes connected to the manhole should have a flexible joint within one pipe diameter beyond the connection (see Figure 5-1).
- 5.5. Minimum slab thickness and reinforcement are specified in Table 1 and Table 2 in the appendices of this publication. (See Appendix A and B)
- 5.6. Concrete slab designs must meet American Concrete Institute Code ACI 318 Building Code Requirements for Structural Concrete with a load factor of 1.3. This is sufficient to resist bending from water head pressure and soil loading with the manhole completely empty with water to grade and a float out Factor of Safety of at least 1.2.

- 5.7. It is the responsibility of the owner or owner's representative to install a slab of adequate design that facilitates proper product use.

Figure 5-1

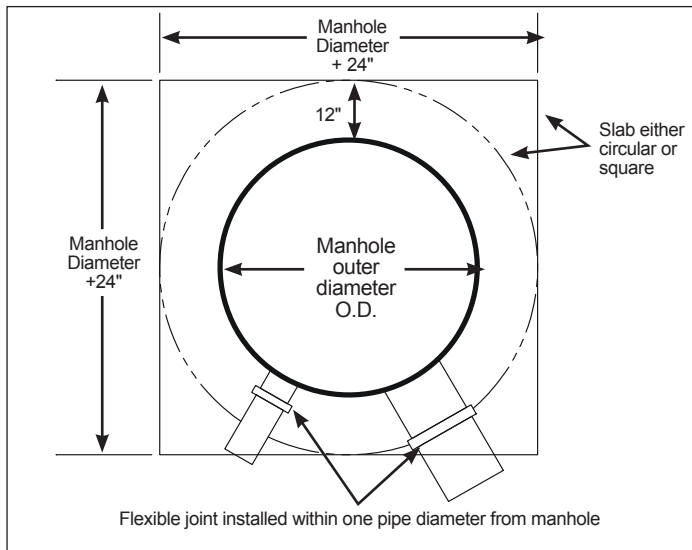

6. MANHOLE POSITIONING

- 6.1. To aid in positioning the manhole while constructing the concrete slab, supports or shims may be utilized (See Figure 6-1).
- 6.1.1. Supports should be made from a material that will not degrade or rot.
- 6.1.2. The manhole must rest on a minimum of 3 evenly spaced supports. The supports should position the manhole bottom above the rebar. Manhole cannot sit on rebar reinforcement.
- 6.1.3. The supports must be in contact with the flat bottom of the manhole at the outside diameter, and must not contact the external structural anchors.
- 6.1.4. The supports must not extend more than 8" from the outside diameter of the manhole toward the center.

Figure 6-1

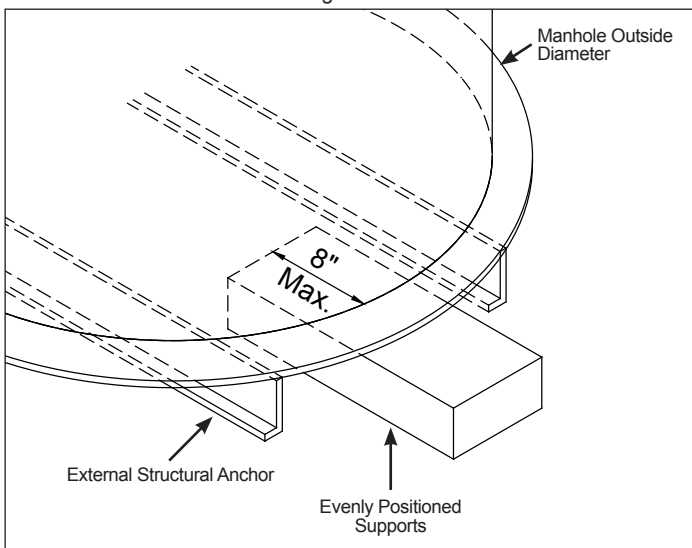

7. BOTTOM SLAB FOR OPEN BOTTOM MANHOLES

WARNING

Collapsing excavation walls can cause injury or death. Do not enter the manhole excavation unless necessary and in compliance with OSHA regulations. Follow OSHA guidelines for excavations.

- 7.1. Open Bottom Manholes with or without optional Anti-Flotation Flange
- 7.1.1. With cutouts made, position manhole so that it may be set in place with backhoe or other lifting device.
- 7.1.2. Lower manhole in place until top of cutout gently rests upon pipe.
- 7.1.3. Plumb manhole and work concrete around manhole and over the pipe, forming a tight seal at least 6" high (See Figure 7-1).
- 7.1.4. Pour a minimum 6" slab with no reinforcement for 48" or smaller diameter. For open bottom manholes greater than 48" diameter, the engineer of record must design the slab thickness to account for water tables as well as any additional concrete poured for the bench and invert.
- 7.1.5. Manhole should be embedded a minimum of 4" into the concrete slab.
- 7.1.6. If infiltration around the inlet and outlet pipe is a concern, a waterstop gasket, placed on the inlet and outlet pipes, is recommended. The gasket is embedded in the concrete work around the pipe.

Figure 7-1

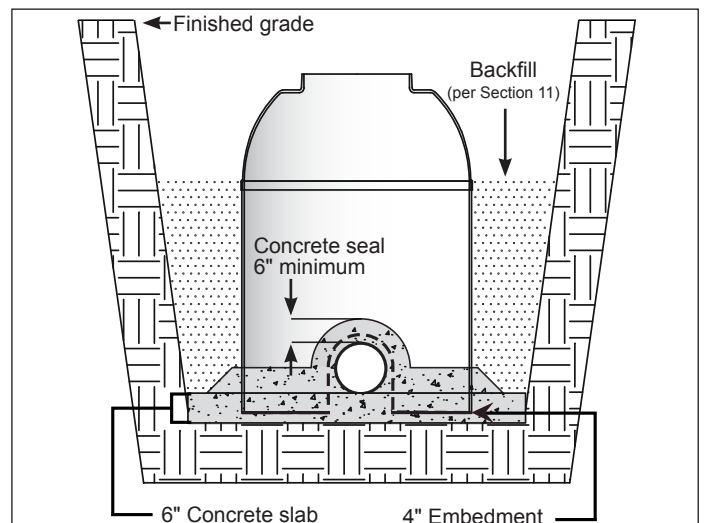

8. CLOSED BOTTOM MANHOLES WITH FACTORY SUPPLIED BOTTOM SLAB

- 8.1. Closed bottom manholes with factory supplied bottom slabs are only available from the manufacturer and do not require additional slab instructions. Lower the complete unit into the excavation using the supplied lift lugs and backfill per Section 11. Make sure the excavation bed is level and free of rocks and debris. All other instructions within this document still apply.

9. BOTTOM SLAB FOR CLOSED BOTTOM MANHOLES WITHOUT EXTERNAL ANCHORS

⚠WARNING

Collapsing excavation walls can cause injury or death. Do not enter the manhole excavation unless necessary and in compliance with OSHA regulations. Follow OSHA guidelines for excavations.

- 9.1. Closed Bottom Manholes without External Structural Anchors (See Figures 9-1 and 9-2 and Appendix A)
 - 9.1.1. Cast in place slab - Lower manhole into wet concrete until it rests at correct elevation embedded 3" into concrete, then move manhole to plumb.
 - 9.1.2. It may be necessary to add ballast (water) inside the manhole to counteract buoyancy until the concrete is cured.
 - 9.1.3. Precast slab - Lower manhole until it rests on the slab. Place a minimum of 3" of concrete on top of precast pad around the circumference of the manhole.

Figure 9-1

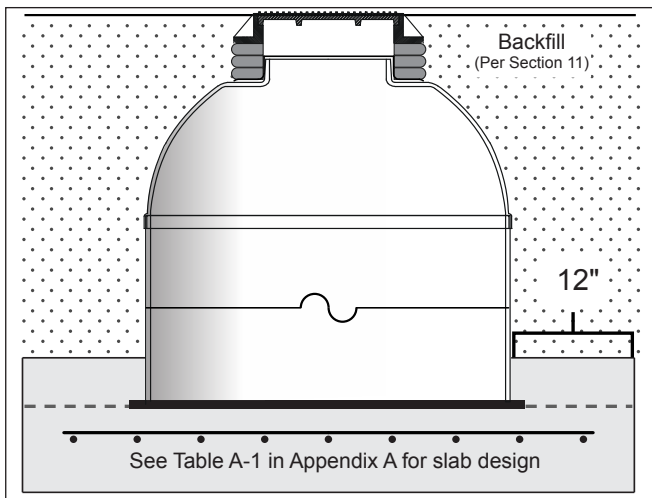
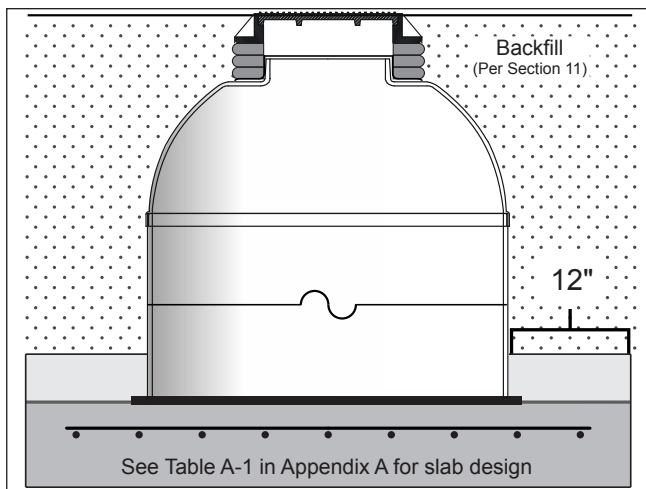

Figure 9-2



10. BOTTOM SLAB FOR CLOSED BOTTOM MANHOLES WITH EXTERNAL ANCHORS

⚠WARNING

Collapsing excavation walls can cause injury or death. Do not enter the manhole excavation unless necessary and in compliance with OSHA regulations. Follow OSHA guidelines for excavations.

- 10.1. Closed Bottom Manholes with External Structural Anchors (See Figure 10-1 and Appendix B)
 - 10.1.1. Cold concrete joints and precast slabs are not allowed. Fiberglass closed (solid) bottom manholes with external structural anchors must be installed in a continuous and monolithic concrete pour including the anti-flotation ring cover (embedding).
 - 10.1.2. Lower manhole into wet concrete until it rests at correct elevation embedded a minimum of 3" into concrete.
 - 10.1.3. Concrete must extend at least 3" above the manhole bottom and around the entire circumference of the manhole.
 - 10.1.4. It may be necessary to add ballast (water) inside the manhole to counteract buoyancy until the concrete is cured.
 - 10.1.5. Push and/or prod the concrete to ensure all voids are filled under and around the external structural anchors.

⚠CAUTION

Voids in the concrete pad around external structural anchors will result in product damage and environmental contamination.

Figure 10-1

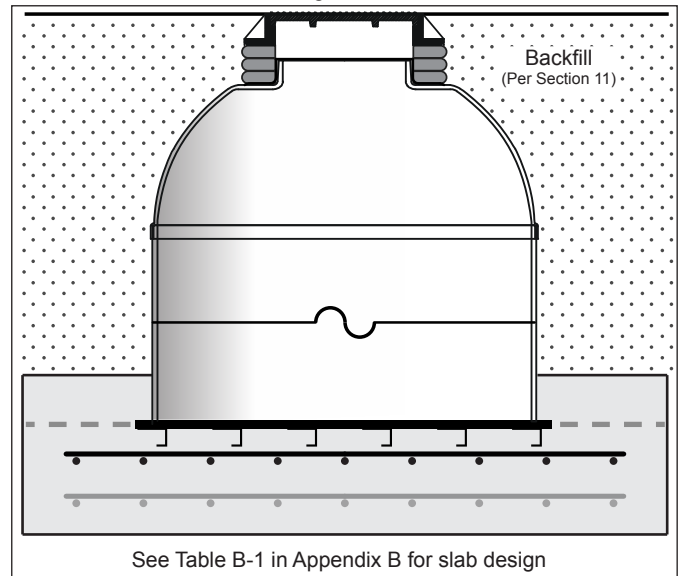

11. BED AND BACKFILL

- 11.1. Proper backfill selection and compaction is required for a proper installation. The allowed backfills are shown in the Backfill & Compaction Tables (See Appendix C) along with the degree of compaction required.
 - 11.1.1. Backfill selection shall be in accordance with these instructions and based on the largest diameter of any section of the manhole.
- 11.2. Do not backfill around the manhole until the concrete slab has hardened.
- 11.3. Add backfill in maximum 12" lifts evenly around the manhole to avoid uneven backfill loads (see Figure 11-1).
- 11.4. A flexible joint on each connecting pipe is required to relieve stresses from differential backfill movement or soil consolidation. Backfill should be added to the invert elevation of each connecting pipe, the connection made and sealed, before continuing to backfill.
- 11.5. Backfill surround requirements:
 - 11.5.1. If muck, bog, peat, or loess are present, consult with a Geotechnical Engineer for backfill and excavation requirements.
 - 11.5.2. For permafrost conditions, consult with a Geotechnical Engineer for backfill and excavation requirements.
 - 11.5.3. Keep backfill dry and free of ice in freezing conditions.
- 11.6. Ensure that no foreign objects larger than 2" such as large stones, concrete clumps, tree roots/limbs, or debris is in the backfill surrounding the manhole.
- 11.7. Prevent large surges of backfill from displacing the manhole.

Figure 11-1

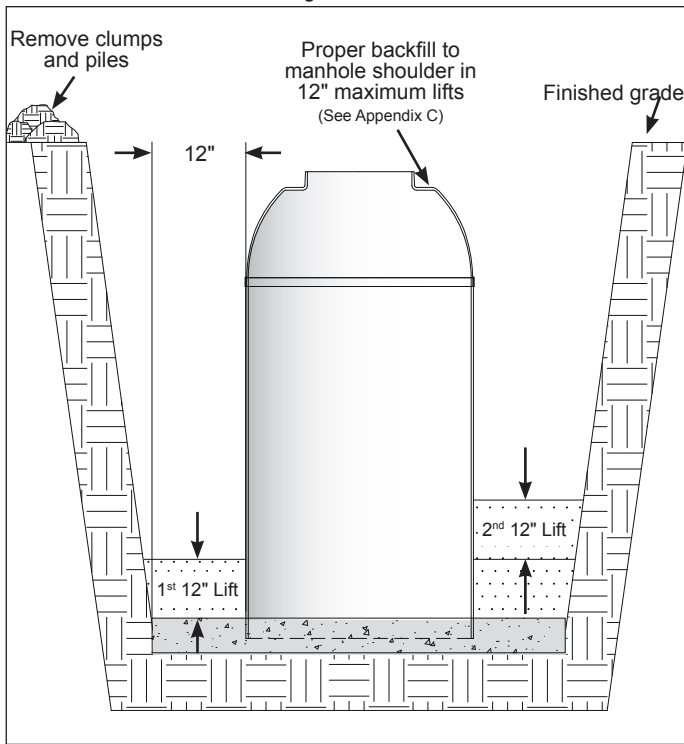

12. MANHOLE INSTALLATION WITH A FIBERGLASS UNDERGROUND TANK

⚠ CAUTION

Not using approved backfill material may result in tank failure and environmental contamination.

- 12.1. If the manhole is installed in the same excavation as an underground fiberglass tank, the backfill around the manhole must also meet the tank backfill requirements so as to not compromise the tank installation.
- 12.2. Tank backfill requirements are more restricted and strict conformance to the tank backfill requirements in INST 6001 must be met for both the manhole and tank.

13. ADHESIVE CHANNEL INSTALLATION INSTRUCTIONS

- 13.1. The manhole/wetwell adhesive joint facilitates a watertight connection between a CSI open bottom manhole and a fiberglass base manhole. These instructions will explain how to properly seal the joint using CSI's EZ-Fit adhesive channels and adhesive kits (KIT-AD).
- 13.2. Read the following instructions before attempting to mix or apply the adhesive material.

13.3. HANDLING & PREPARATION

⚠ CAUTION

In freezing conditions, protect adhesive channel from water accumulation. Freezing water may cause damage.

- 13.3.1. Visually inspect the riser components for shipping or handling damage. If damage is found, contact CSI Field Service.
- 13.3.2. Wear gloves.
- 13.3.3. Do not roll, drop or bounce manhole.
- 13.3.4. All assembly kits (Kit-AD or Kit-LK) should be stored in a cool/dry location at 50° - 70°F. Higher temperature will shorten shelf life. Use by expiration date shown on the box label.

13.4. ASSEMBLY INSTRUCTIONS

- 13.4.1. Dry fit all manhole components prior to installation.
- 13.4.2. Remove any rocks, and/or debris from adhesive channel.
- 13.4.3. Using a contractor supplied 40-grit grinding disc, grind all mating surfaces until white in color.
- 13.4.4. Ensure mating surfaces are free of contaminants.
- 13.4.5. Do not use oil-based solvents, soap, or water to clean surfaces.
- 13.4.6. Position manhole inside EZ-Fit adhesive channel.
- 13.4.7. Confirm that surfaces and/or adhesive channels are dry and clean before mixing or applying the adhesive.

13.5. ADHESIVE INSTRUCTIONS

- 13.5.1. CSI manholes must be installed using only CSI supplied adhesive kits.

⚠ WARNING

Always wear protective goggles and gloves when mixing and applying adhesive and resin. The liquid materials are flammable. Keep adhesive and resin away from sparks and ignition sources.

NOTE: After mixing adhesive and hardener, you will have no more than 20 minutes to complete the application before the resin begins to harden.

13.5.2. TEMPERATURE CONSIDERATIONS:

- Recommended method for supplemental heat is to transfer warm air to the manhole while keeping ignition sources away.

13.5.3. Cool Weather (less than 60°F):

- Preheat the adhesive to 60-75°F.
- Before adhesive is applied, add supplemental heat. Apply heat to keep joint surfaces over 60°F.
- After adhesive is applied, continue to apply supplemental heat until it hardens (30 minutes min.).

13.5.4. Warm Weather (between 61°F and 85°F):

- Adhesive will harden in approximately 30 minutes.
- No supplemental heat required.

13.5.5. Hot Weather (above 85°F):

- Apply adhesive more rapidly (adhesive may harden in less than 10 minutes).
- To increase working time, cool the adhesive to 60°F to slow down chemical reaction.

13.5.6. KIT CONTENTS: This kit is designed for Adhesive Joints.

Items	Size	Qty.
Mix Instructions Sheet (INST 6051)		1
MSDS for Adhesive Mix (INST 6023)		1
MSDS for Catalyst (Cadox L-50A)		1
Styrene Warning		1
Putty Knife		1
Adhesive Mix (Part A)	1 gal.	1
Catalyst (Part B)	5 gm tubes	12
Grout Bag		1
Mixing Stick		1

- Dry fit all manhole components prior to sealing joints, as outlined in Section 13.4.
- Thoroughly mix two part adhesive by hand or with a powered mixer following the mixing instructions contained in the adhesive kit.
- Apply the adhesive with the supplied grout bag and putty knife. Fill the adhesive channel from outside of the manhole (see Figure 13-1).

Figure 13-1

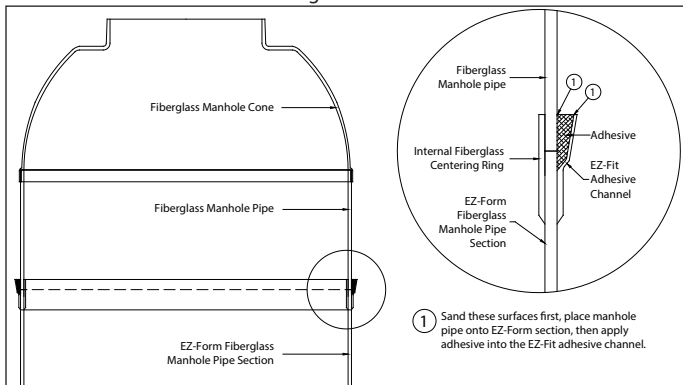

- All adhesive must be dispensed at the time of installation, so if two adhesive kits are required based on manhole diameter, both kits must be thoroughly mixed, poured into grout bags and emptied into the adhesive channel simultaneously.

- Fill the channel with the appropriate cans of adhesive per the chart in Table 3-1.

Table 3-1

MANHOLE DIAMETER	NUMBER OF KITS
48"	4
54"	4
60"	5
66"	5
72"	6
92"	7
96"	7
120"	9

- Allow adhesive to cure at least 5 hours without moving the joined parts. The surface of the adhesive should be hard; if not hard after 5 hours, wait up to 24 hours.
- Properly dispose of any unused adhesive kit contents by following the mixing instructions contained in the adhesive kit.

14. FINISHING MANHOLE TO GRADE

CAUTION

Only load manholes on the flat shoulder using adjustment rings and cast-iron covers. Never directly load a manhole.

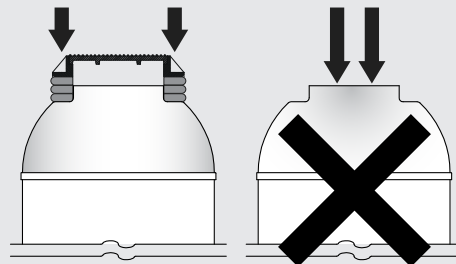

- 14.1. Construct a chimney on the manhole flat base, also referred to as the shoulder, using adjustment rings.
- 14.2. Place a mortar bed on the shoulder for the first adjustment ring. the mortar bed ensures the load is spread on the brick ledge thereby avoiding concentrated loading at points on the brick ledge.
- 14.3. The chimney is used to support the ring and cover (see Figure 14-1).

Figure 14-1

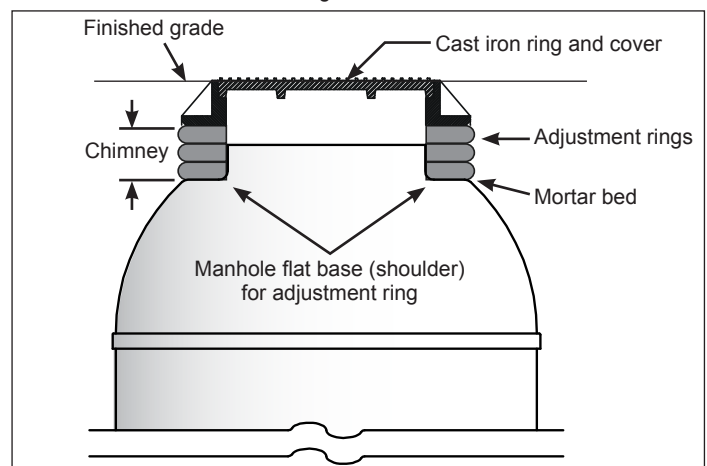

- 14.4. DO NOT place cast-iron ring directly on manhole.
- 14.5. DO NOT bolt or otherwise secure the grade ring to the fiberglass manhole.

15. FLEXIBLE BOOT INSTALLATION

⚠ CAUTION

Failure to install accessories according to product manufacturer's instructions may result in improper connections and or environmental contamination.

- 15.1. Flexible boots, and any other pipe installation, must be installed and used in strict accordance with the product manufacturer's instructions.
- 15.2. All piping connections must be self supported by bedding or backfill.
- 15.3. Flexible boots must be centered on the incoming pipe. To assure centering, measure the boot fiberglass sleeve centering (see Figures 15-1 and 15-2).

Figure 15-1

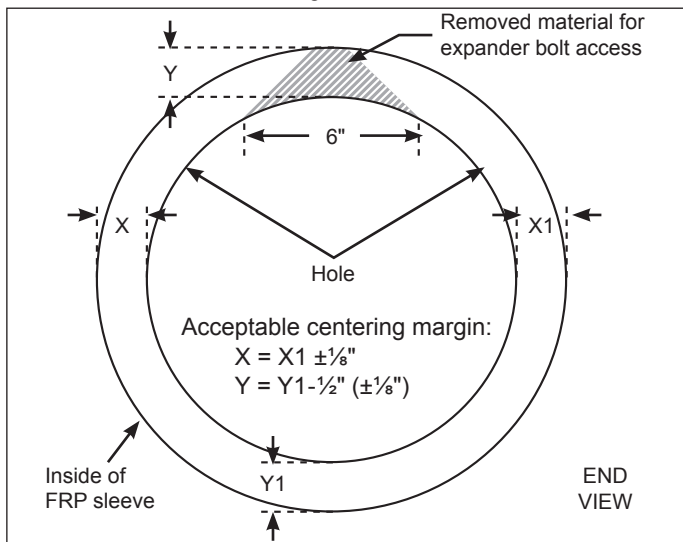
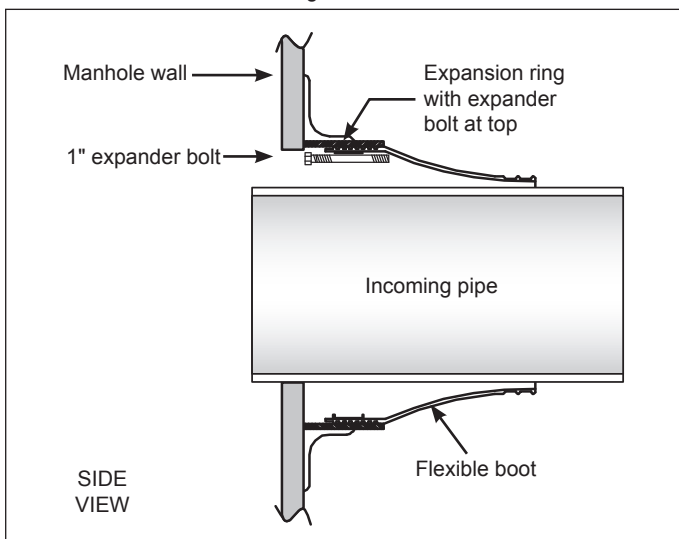

Figure 15-2



16. OPERATING GUIDELINES

16.1. General

- 16.1.1. For the life of the installation, all applicable Federal, State, Local or Provincial codes and regulations must be complied with.
- 16.1.2. It is the responsibility of the manhole owner/operator to follow these instructions and operating guidelines and all limitations as stated in the limited warranties in effect at time of delivery.
- 16.1.3. The limited warranty in effect at the time of manhole delivery will apply and is available online at www.containmentsolutions.com.

16.2. Fiberglass Manholes Intended Use

- 16.2.1. Each manhole is designed and manufactured to store products for the intended use as outlined in the applicable limited warranty. Storing products that were not disclosed to CSI in writing prior to the manufacture of the manhole may damage the manhole and could result in manhole failure and/or damage to surrounding property.
- 16.2.2. The temperature of stored product must not exceed the temperature limits defined in the applicable limited warranty.
- 16.2.3. Product delivery temperatures must not exceed the temperature limits defined in the applicable limited warranty.

16.3. Confined Space Entry

⚠ WARNING

Do not enter manhole unless following OSHA guidelines for confined space entry. Failure to follow OSHA guidelines could result in death or serious injury.



ASPHYXIATION



FIRE



EXPLOSION

- 16.3.1. Manhole structures are confined spaces.
- 16.3.2. The manhole owner should not allow anyone other than properly trained and equipped personnel to enter an underground manhole.
 - 16.3.2.1. Proper permits and industry accepted minimum standards must be followed before anyone can enter a manhole.
 - 16.3.2.2. Contact Containment Solutions Field Services at (800) 822-1997 if repairs or modifications are required.
- 16.3.3. Manhole entry by unqualified personnel can lead to fire, explosion, asphyxiation and/or death. Manways and access risers are for use by qualified personnel with proper training and safety equipment.
- 16.3.4. Do not attempt to repair or modify your manhole. Any repairs or modifications will void the manhole limited warranty.
- 16.3.5. If manhole entry is required for repairs, modifications or inspections, contact Containment Solutions Field Services at (800) 822-1997.

APPENDIX A - MANHOLES WITHOUT EXTERNAL ANCHORS

Closed bottom manholes WITHOUT external anchors:

The diagram below defines the measurements utilized in Table A-1 for designing concrete slabs suitable for use with Containment Solutions products. Slabs are designed to ACI code to resist buckling from external water pressure in the installed condition with the perimeter of the manhole embedded in concrete. Use a minimum 3000 psi concrete and 60 ksi yield strength rebar. Each manhole must rest on, or be embedded in, a concrete bottom slab.

Definitions:

- (A) Concrete Thickness Under Manhole - measured from the bottom of the slab to the bottom of the manhole.
- (B) Total Slab Thickness - the total concrete height including the 3" of concrete embedment around the anti-flotation flange.
- (C) Rebar Size - the rebar number based on the diameter of the rod in 1/8" increments.
- (D) Rebar Spacing - the center-to-center distance within a rebar layer.
- (E) Slab Extension - the minimum allowed concrete beyond the manhole outer diameter (O.D.)
- (F) Top Layer Rebar Cover Depth - minimum concrete depth between bottom of manhole and top of rebar.

FIGURE A-1

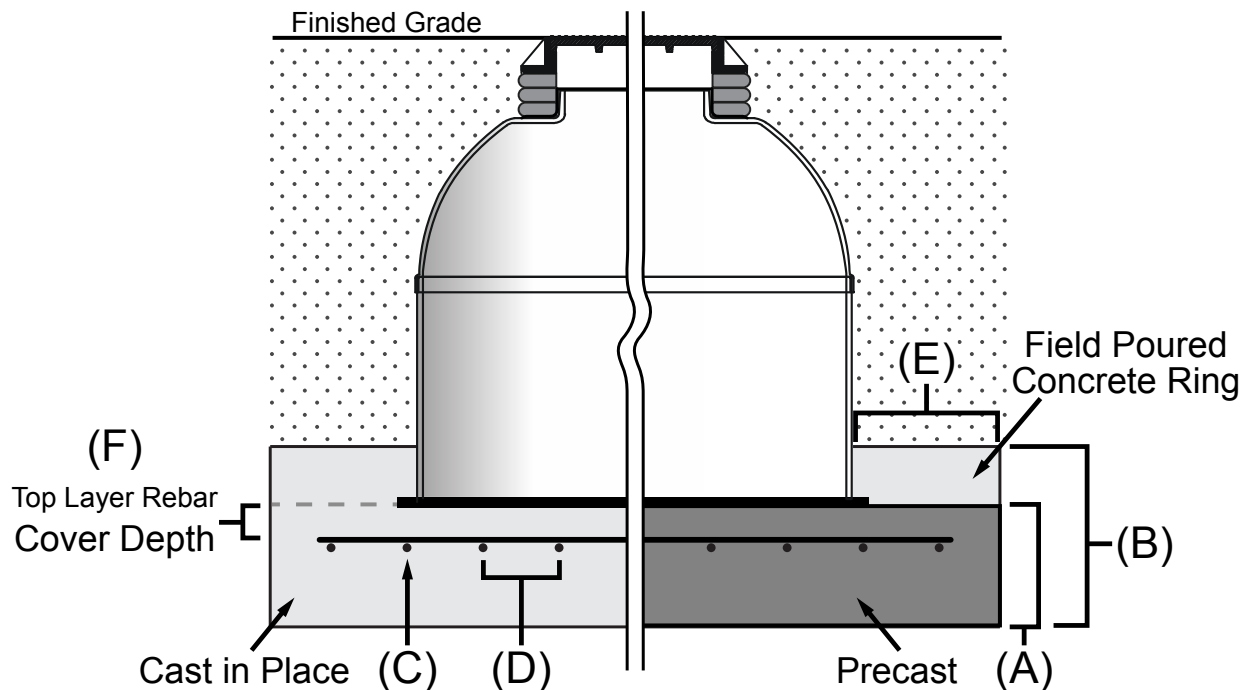

Additional Instructions:

1. A layer of rebar includes rebar placed with the bottom rows laying perpendicular to the top rows, with specified rebar cover depth (F) between top of rebar and manhole bottom.
2. All rebar to extend to within 2" of the slab perimeter.
3. The rebar cover depth may not be changed, but the rebar size and spacing within a layer may be adjusted as long as the amount of steel specified in Table A-1 is matched or exceeded.
4. Each manhole slab must be independent of any other slab or structure.
5. Cast in place or precast slabs are acceptable for closed bottom manholes without structural anchors.

APPENDIX A - MANHOLES WITHOUT EXTERNAL ANCHORS

Closed Bottom Manholes WITHOUT External Anchors:

The measurements identified in the table below are referenced in Figure A-1.

TABLE A-1

Manhole Diameter	Depth (feet)	Concrete Thickness Under Manhole (inches)	Total Slab Thickness (including 3" Embedment) (inches)	Rebar Size (number)	Rebar Spacing (inches)	Slab Extension (inches)	Top Rebar Cover Depth (inches)
		A	B	C	D	E	F
36"	1-10	6	9	5	28	12	1.5
	11-20	6	9	5	28	12	1.5
	21-30	6	9	5	28	12	1.5
	31-40	6	9	5	28	12	1.5
	41-50	6	9	5	26	12	1.5
42"	1-10	6	9	5	28	12	1.5
	11-20	6	9	5	28	12	1.5
	21-30	6	9	5	28	12	1.5
	31-40	6	9	5	26	12	1.5
	41-50	6	9	5	23	12	1.5
48"	1-10	6	9	5	28	12	1.5
	11-20	6	9	5	28	12	1.5
	21-30	6	9	5	26	12	1.5
	31-40	6	9	5	21	12	1.5
	41-50	7	10	5	20	12	1.5
54"	1-10	6	9	5	28	12	1.5
	11-20	6	9	5	26	12	1.5
	21-30	6	9	5	23	12	1.5
	31-40	6	9	5	17	12	1.5
	41-50	7	10	5	17	12	1.5
60"	1-10	6	9	5	28	12	1.5
	11-20	6	9	5	26	12	1.5
	21-30	6	9	5	18	12	1.5
	31-40	7	10	5	17	12	1.5
	41-50	7	10	5	14	12	1.5
66"	1-10	6	9	5	28	12	1.5
	11-20	6	9	5	23	12	1.5
	21-30	6	9	5	15	12	1.5
	31-40	7	10	5	14	12	1.5
	41-50	8	11	5	14	12	1.5
72"	1-10	6	9	5	28	12	1.5
	11-20	6	9	5	19	12	1.5
	21-30	6	9	5	12	12	1.5
	31-40	7	10	5	12	12	1.5
	41-50	8	11	5	16	12	1.5

APPENDIX B - MANHOLES WITH EXTERNAL ANCHORS

Closed Bottom Manholes WITH External Anchors:

The diagram below defines the measurements utilized within Table B-1 for designing concrete slabs suitable for use with Containment Solutions products. Slabs are designed to ACI code to resist buckling from external water pressure in the installed condition with the perimeter of the manhole embedded in concrete. Use a minimum 3000 psi concrete and 60 ksi yield strength rebar. Each manhole must be embedded in a concrete bottom slab.

Definitions:

- (A) Concrete Thickness Under Manhole - measured from the bottom of the slab to the bottom of the manhole.
- (B) Total Slab Thickness - measured from the bottom of the slab to the top of the concrete embedment.
- (C) Rebar Size - the rebar number based on the diameter of the rod in $\frac{1}{8}$ " increments.
- (D) Rebar Spacing - the center-to-center distance within a layer.
- (E) Slab Extension - the minimum allowed concrete beyond the manhole outer diameter (O.D.)
- (F) Top Layer Rebar Cover Depth - minimum concrete depth between bottom of manhole and top of rebar.

FIGURE B-1

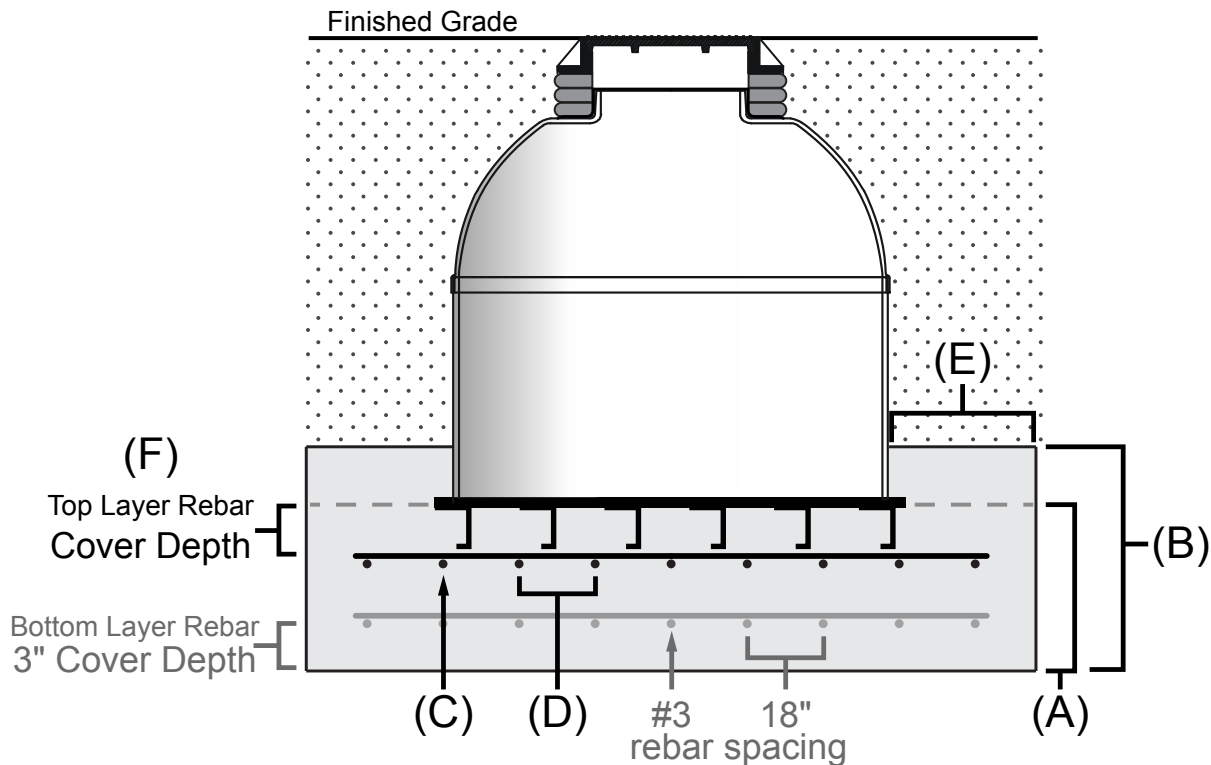

Additional Instructions:

1. The Top Layer Rebar, (C) & (D), is required on all slabs, reference Table B-1 for size and spacing. Place bottom rows of rebar perpendicular to top rows of rebar with specified cover depth (F) between top rebar and manhole bottom.
2. A Bottom Layer Rebar is only when indicated on Table B-1. Place bottom rows of rebar perpendicular to top rows of rebar with 3" of cover depth (between the bottom of slab and bottom rebar). When bottom layer rebar is required, use #3 rebar and 18" spacing.
3. All rebar to extend to within 2" of the slab perimeter.
4. Each manhole must be independent of any other manhole or other structures.
5. For a layer of rebar, the rebar cover depth may not be changed, but the rebar size and spacing within a layer may be adjusted as long as the amount of steel specified in Table B-1 is matched or exceeded.

APPENDIX B - MANHOLES WITH EXTERNAL ANCHORS

Closed Bottom Manholes WITH External Anchors:

The measurements identified in the table below are referenced in Figure B-1.

TABLE B-1

NOTE: Concrete pad with 1 layer of rebar each way at top with 5" of cover (distance between top of rebar and flat of manhole bottom). Rebar to extend to within 2" of the pad perimeter and have hooks at each end extending toward the pad bottom to within 2" of the bottom.

Manhole Diameter	Depth (feet)	Concrete Thickness Under Manhole (inches)	Total Slab Thickness (including 3" Embedment) (inches)	Rebar Size (number)	Rebar Spacing (inches)	Slab Extension (inches)	Top Rebar Cover Depth (inches)
		A	B	C	D	E	F
36"	1-10	7	10	5	24	12	5
	11-20	8	11	5	21	12	5
	21-30	8	11	5	21	12	5
	31-40	9	12	5	18	12	5
	41-50	9	12	5	18	12	5
42"	1-10	8	11	5	21	12	5
	11-20	8	11	5	21	12	5
	21-30	8	11	5	21	12	5
	31-40	9	12	5	18	12	5
	41-50	10	13	5	17	12	5
48"	1-10	8	11	5	21	12	5
	11-20	8	11	5	21	12	5
	21-30	9	12	5	18	12	5
	31-40	9	12	5	18	12	5
	41-50	10	13	5	17	12	5
54"	1-10	8	11	5	21	12	5
	11-20	8	11	5	19	12	5
	21-30	9	12	5	18	12	5
	31-40	10	13	5	17	12	5
	41-50	11	14	5	15	12	5
60"	1-10	8	11	5	21	12	5
	11-20	8	11	5	14	12	5
	21-30	9	12	5	15	12	5
	31-40	10	13	5	15	12	5
	41-50	11	14	5	15	12	5
66"	1-10	8	11	5	21	12	5
	11-20	9	12	5	18	12	5
	21-30	9	12	5	12	12	5
	31-40	10	13	5	12	12	5
	41-50	11	14	5	12	12	5
72"	1-10	8	11	5	21	12	5
	11-20	9	12	5	16	12	5
	21-30	10	13	5	14	12	5
	31-40	11	14	5	13	12	5
	41-50	12	15	5	13	12	5

Notes:

- For manhole diameters larger than 72", refer to the latest version of the Wetwell Installation Instructions (Pub. No. MAN 4004).

APPENDIX C - BACKFILL & COMPACTION TABLES

TABLE C-1

Diameter	Smooth Wall Cylinder			Ribbed Cylinder Manhole		
	<= 72" diameter*			> 72" diameter*		
Depth	0' - 20'		21' - 50'	0' - 20'		21' - 50'
Soil Type	Stable Soils AND Water Table more than 5' below grade	Unstable Soils OR water table less than 5' below grade	All Soils	Stable Soils AND Water Table more than 5' below grade	Unstable Soils OR water table less than 5' below grade	All Soils
	Bearing capacity greater than 2000 lbs. per sq. ft.	Bearing capacity less than 2000 lbs. per sq. ft. (Ex: include expansive clay, quick sand or marsh)		Bearing capacity greater than 2000 lbs. per sq. ft.	Bearing capacity less than 2000 lbs. per sq. ft. (Ex: include expansive clay, quick sand or marsh)	
Backfill Type Allowed	Native Soil	Backfill per Table 11-2		Backfill per Table 11-2		
Compaction	Dumped	Compaction per Table 11-2		Compaction per Table 11-2		
Backfill Around Cylinder	12"	24"	24"	24"	½ Diameter	½ Diameter
Max Lifts	12"	12"	12"	12"	12"	12"

* 72" diameter manhole cylinders less than 20' deep will be smooth wall, 72" diameter manholes equal to or greater than 20' deep will be ribbed.

TABLE C-2

Bed and Backfill Compaction	
Soil type-pipe bedding material (Unified Soil Classification System) (See Table 11-3)	Minimum Degree of Compaction Required*
Fine - grained soils (Liquid Limit < 50) with medium to no plasticity with less than 25% coarse grained particles. CL, ML, ML - CL,	High
Fine grained soils (Liquid Limit < 50) with medium to no plasticity with more than 25% coarse grained particles. CL, ML, ML - CL	Moderate
Coarse grained soils containing more than 12% fines. GM, GC, SM, SC	Moderate
Coarse grained soils with less than 12% fines. GW, GP, SW, SP	Moderate
Crushed Rock or Pea Gravel (¾" maximum size with less than 50% passing No. 4 sieve)	Dumped
* Degree of compaction: <ul style="list-style-type: none"> • Dumped - No compaction effort. • Moderate - Intermediate level of compactive effort, In-place density >=85% and < 95% standard Proctor Density, or >=40% and <70% Relative Density. • High - Considerable compactive effort. In-place density >= 95% standard Proctor Density, or >= 70% Relative Density. 	

TABLE C-3

First Letter		Second Letter	
Letter	Definition	Letter	Definition
G	Gravel	P	Poorly Graded (uniform particle sizes)
S	Sand	W	Well Graded (diversified particle sizes)
M	Silt	H	High Plasticity
C	Clay	L	Low Plasticity
O	Organic		

The Unified Soil Classification System can be applied to most unconsolidated materials, and is represented by a two-letter symbol.



CONTAINMENT
SOLUTIONS®

333 North Rivershire Dr, Suite 190 Conroe, Texas 77304
Tel: 936-756-7731 Fax: 936-756-7766
www.containmentsolutions.com